



Montana Department of Transportation Bridge Bureau Approved Construction Equipment List

This form is used for analyses for Bridge Approval Only.

Make **Model**

Combination Type **If Other (Specify)**

Select Axle Type

Select # of Axles

Insert Weight (lbs)

	Axle Groups	Feet	Inches
	<input type="text"/>	<input type="text"/>	<input type="text"/>

Comments

Vehicle configuration, weights and specifications on following pages. Approved statewide on non-load posted Bridges, using operating weights, when centerlining and soloing bridges at 10mph. For vehicle movement on Bridges with structural reduced capacity see, Br201.38, here: <https://www.mdt.mt.gov/business/contracting/bridge/bridge-specials.aspx>

CAT PM620 and PM622

- The Caterpillar PM620 cold miller (shown below) fully loaded qualifies for statewide permit driving only under solo and centerline conditions.
- The Caterpillar PM622 cold miller (shown below) at the transport weight of 66,139 lbf qualifies for statewide permit driving under no speed or lane restrictions.

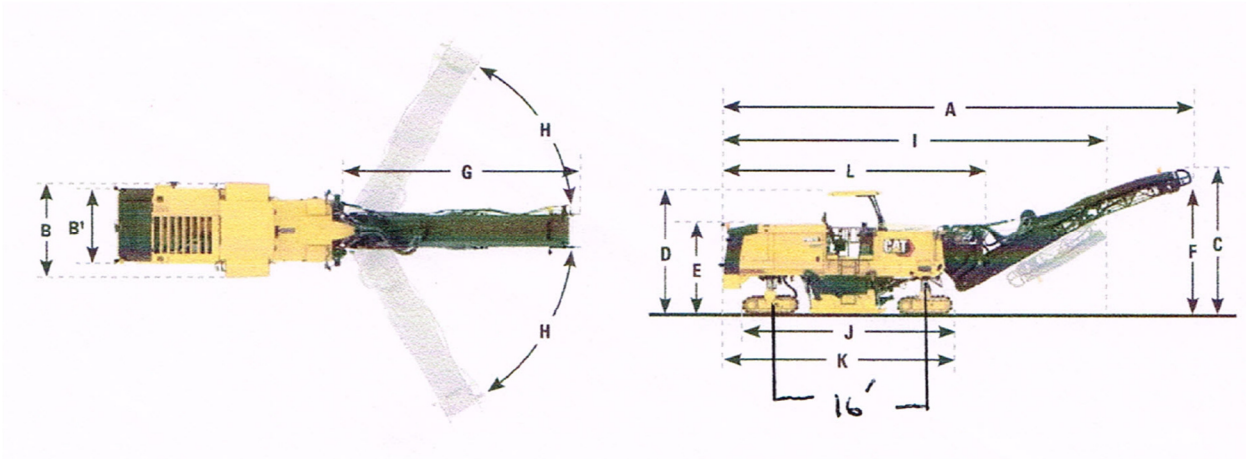

ENGINE	
Engine Model	Cat C18
Gross Power – SAE J1995	470 kW 630 hp
Gross Power – ISO 14396	462.5 kW 620.2 hp
Emissions	
– U.S. EPA Tier 4 Final, EU Stage V, Korea Tier 4 Final	
– Brazil MAR-1 and China Nonroad Stage III emission standards, equivalent to U.S. EPA Tier 3 and EU Stage IIIA	
Operating Speed	100 m/min 328 ft/min
Maximum Travel Speed	5.9 km/h 3.7 mph

CUTTING SYSTEM	
PM620 Milling Width	2010 mm 79.1 in
PM620 Number of Bits (15 mm spacing)	178
PM622 Milling Width	2235 mm 88.0 in
PM622 Number of Bits (15 mm spacing)	185
Maximum Cutting Depth	330 mm 13.0 in
Rotor Speeds	100 / 109 / 118 rpm
Minimum Left Cutting Radius	2.00 m 6.56 ft
PM620 Minimum Right Cutting Radius	2.00 m 6.56 ft
PM622 Minimum Right Cutting Radius	1.80 m 5.91 ft

MACHINE WEIGHT	
PM620 Operating Weight	33 330 kg 73,480 lb
PM620 Transport Weight	29 430 kg 64,882 lb
PM622 Operating Weight	33 900 kg 74,737 lb
PM622 Transport Weight	30 000 kg 66,139 lb

Weights shown are approximate and include:

- Operating weights include coolants, lubricants, full fuel tank, full water tank and 75 kg (165 lb) operator.
- Transport weights include coolants, lubricants, 50% full fuel tank and empty water tank.

SERVICE REFILL CAPACITIES	
Fuel Tank	1108 L 292.7 gal
Diesel Exhaust Fluid (DEF) Tank	47 L 12.4 gal
Cooling System	85 L 22.5 gal
Engine Oil	65 L 17.2 gal
Hydraulic Oil	113 L 29.9 gal
Water Tank	3400 L 898.2 gal

DIMENSIONS	
A Overall Length (conveyor raised)	14.52 m 47.64 ft
B PM620 Maximum Machine Width	3.11 m 10.20 ft
PM622 Maximum Machine Width	3.11 m 10.20 ft
B' PM620 Minimum Machine Width	2.48 m 8.14 ft
PM622 Minimum Machine Width	2.71 m 8.89 ft
C Maximum Height (conveyor raised)	5.23 m 17.16 ft
D Height to Optional Canopy	4.05 m 13.29 ft
E Height (canopy lowered/no canopy)	3.00 m 9.84 ft
F Maximum Truck Clearance	4.86 m 15.94 ft
G Conveyor Length	8.38 m 27.49 ft
H Conveyor Swing	±60° from center

SHIPPING DIMENSIONS	
I Transport Length	12.43 m 40.78 ft
B' PM620 Transport Width	2.48 m 8.14 ft
B' PM622 Transport Width	2.71 m 8.89 ft
E Transport Height (canopy lowered)	3.00 m 9.84 ft
J Length (track to track)	6.69 m 21.95 ft
K Length of Machine (front track to rear)	7.32 m 24.02 ft
L Length of Base Machine	8.33 m 27.33 ft