

SURVEY

DESIGN

RIGHT OF WAY

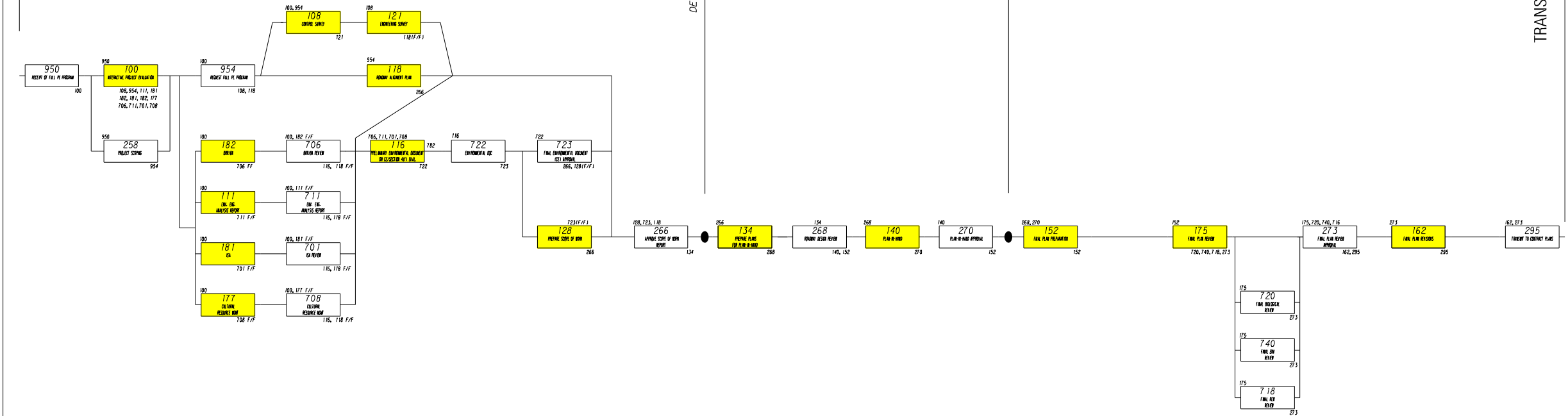

TRANSPORTATION ALTERNATIVES

= Consultant responsible activity

REVISED	AUG 12, 2016	J. PIRRE
REVISED		
REVISED		
REVISED		