

CURB RETURN FILLET REQUIRED FOR NEW CURB & GUTTER INSTALLATIONS (TYPICAL)

EXISTING CURB & GUTTER INSTALLATION WITHOUT CURB RETURN FILLET

NOTE: INCLUDE COST OF CONCRETE FILLET IN VALLEY GUTTER.

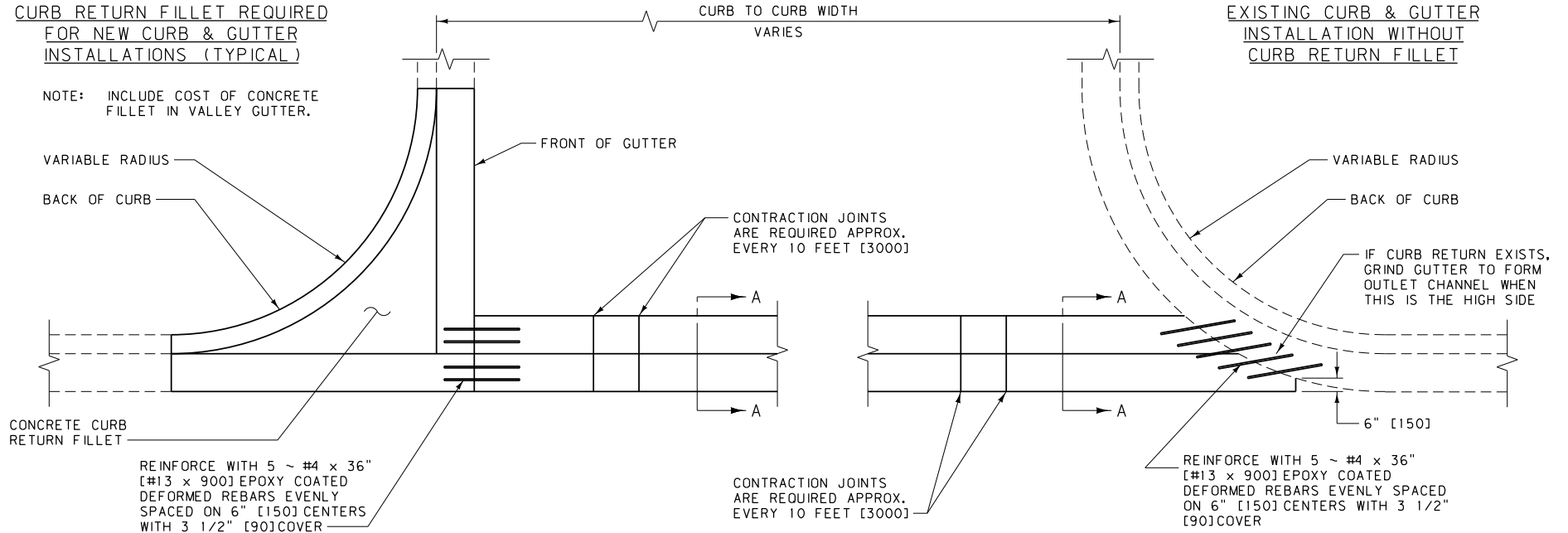

PLAN

NOTES:

- ① INDIVIDUAL LOCATIONS MAY REQUIRE MORE DETAILS FOR ELEVATIONS AND DIMENSIONS.
- ② INSTALL REINFORCEMENT AT ALL CONSTRUCTION JOINTS.
- ③ CONTRACTION JOINTS ARE 1/8" [3 mm] MIN. AND 3/8" [10 mm] MAX. IN WIDTH. FORM JOINTS BY SAWING OR SCORING TO A MINIMUM DEPTH OF 1" [25 mm]. FORM SCORED JOINTS BY A TOOL WHICH WILL LEAVE ROUNDED CORNERS AND DESTROY AGGREGATE INTERLOCK TO A MINIMUM DEPTH OF 1" [25 mm].
- ④ TO BE USED ON PLANT MIX SURFACING PROJECTS ONLY. PROVIDE PROJECT SPECIFIC DETAILS FOR PCCP PROJECTS.

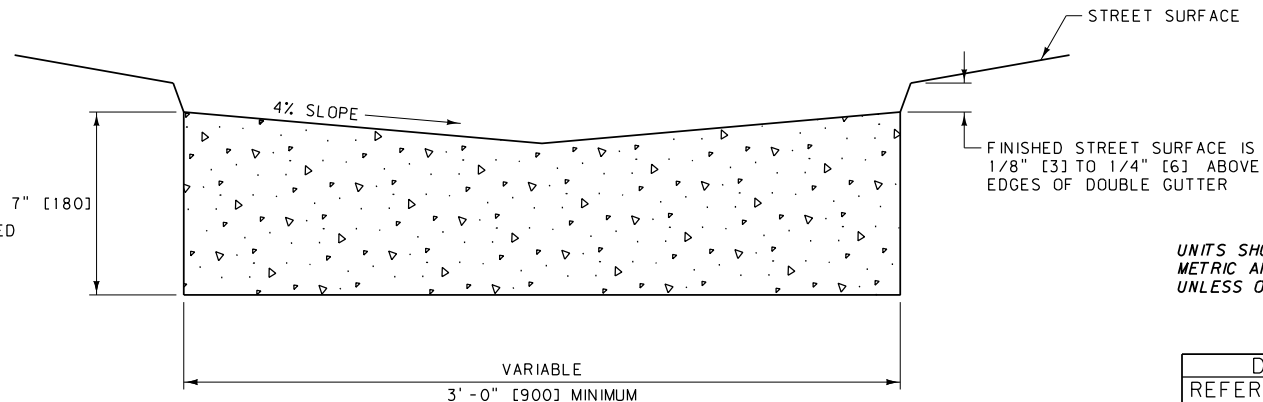

SECTION A-A

UNITS SHOWN IN BRACKETS [] ARE METRIC AND ARE IN MILLIMETERS (mm) UNLESS OTHER UNITS ARE SHOWN.

DETAILED DRAWING	
REFERENCE STANDARD SPEC. SECTION 609	DWG. NO. 609-00
CONCRETE VALLEY GUTTER	
--REVISED-- JULY 2016	EFFECTIVE: SEPTEMBER 2014
 MONTANA DEPARTMENT OF TRANSPORTATION	

CONCRETE CURBS

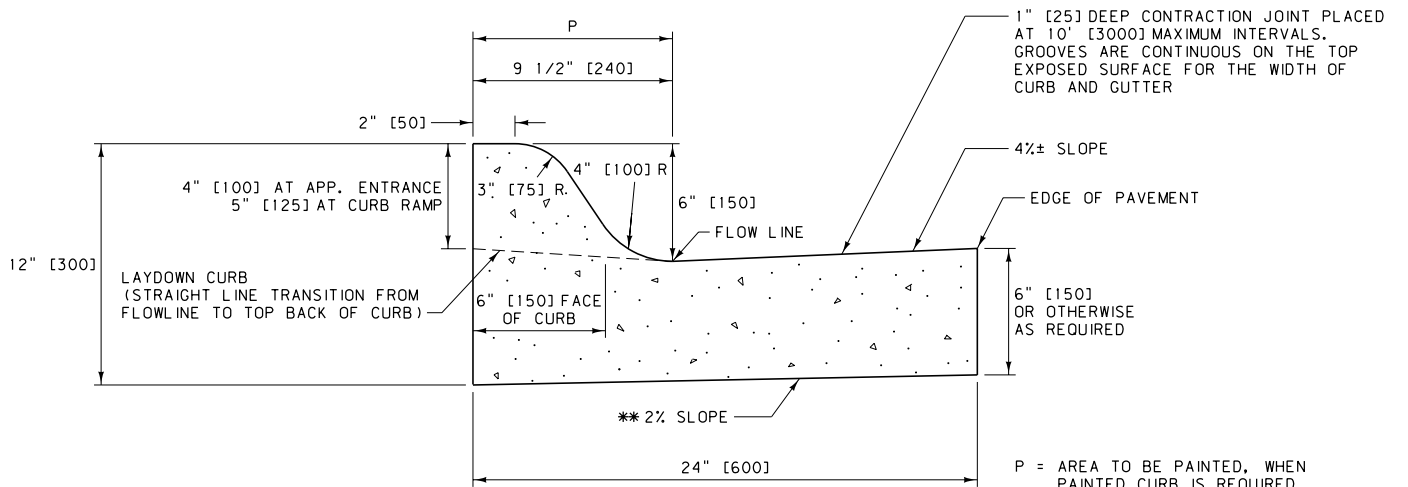

CURB & GUTTER SECTION

0.048 C. Y. CONC. PER 1.0'
[0.110 CUBIC METERS CONC. PER METER]
OF CURB FOR 6" [150] GUTTER. *

JOINTS:

(A) WHEN INTEGRAL WITH, TIED TO, OR PLACED AGAINST PORTLAND CEMENT CONCRETE PAVEMENT (P.C.C.P.): MATCH TRANSVERSE CONTRACTION AND/OR EXPANSION JOINTS IN THE ADJACENT P.C.C.P. SLAB. IF REQUIRED, EXTEND 1/2" [13] MIN. WIDTH PREFORMED EXPANSION JOINTS COMPLETELY THROUGH CURB AND GUTTER THE SAME WIDTH AS THE P.C.C.P. SLAB JOINT. FILL CURB AND GUTTER EXPANSION JOINTS WITH PREFORMED EXPANSION JOINT FILLER.

(B) ALL OTHER CASES:
SPACE CONTRACTION JOINTS IN CURB AND GUTTER AT 10 FOOT [3000] INTERVALS OR LESS EXCEPT AS SPECIFIED IN (A) ABOVE. EXTEND 1/2" [13] MIN. WIDTH EXPANSION JOINTS COMPLETELY THROUGH CURB AND GUTTER EVERY 100 FEET [30 m] (± 30 FEET [10 m]), AT INTERVALS EQUAL TO THE NEAREST MULTIPLE OF THE CONTRACTION JOINT INTERVAL, AND FILL WITH EXPANSION JOINT FILLER.

(C) CONTRACTION JOINTS:
CONTRACTION JOINTS ARE 1/8" [3] MIN. AND 3/8" [10] MAX. IN WIDTH. FORM JOINTS BY SAWING OR SCORING TO A MINIMUM DEPTH OF 1" [25]. FORM SCORED JOINTS BY A TOOL WHICH WILL LEAVE ROUNDED CORNERS AND DESTROY AGGREGATE INTERLOCK TO A MINIMUM DEPTH OF 1" [25].

(D) OTHER JOINTS:
SEPARATE THE CURB AND GUTTER FROM ADJACENT SIDEWALK AT POINTS SHOWN ON DTL. DWG. NO. 608-05 WITH A BOND BREAKER MATERIAL, EXCEPT AT APPROACH LAYDOWN CURB LOCATIONS, WHICH REQUIRE SEPARATION USING 1/2" [13] MIN. WIDTH PREFORMED EXPANSION JOINT MATERIAL. PLACE 1/2" [13] MIN. WIDTH PREFORMED EXPANSION JOINT MATERIAL AT ALL CURB RETURNS, BRIDGES, DROP INLETS, AND WHERE MEETING CURB AND GUTTER IN PLACE.

EXPANSION JOINT FILLER MATERIAL:

USE PREFORMED EXPANSION JOINT FILLER MEETING THE REQUIREMENTS OF SECTION 707.

BOND BREAKER MATERIAL:

USE A 15 OR 30 POUND [6.8 OR 13.6 KILOGRAM] ROOFING FELT MATERIAL, OR OTHER PRODUCT AS APPROVED BY THE PROJECT MANAGER. DO NOT USE EXPANSION JOINT MATERIAL.

RADI:

MINIMUM CURB RETURN RADIUS = 10' [3000]. 15' [4500] RADIUS ARE DESIRABLE FOR STREETS.

CONCRETE:

UNLESS OTHERWISE SPECIFIED, CONSTRUCT CONCRETE CURBS AND CONCRETE INTEGRAL CURB AND GUTTER WITH CLASS GENERAL CONCRETE OR APPROVED EQUAL.

* QUANTITIES FOR ESTIMATING PURPOSES ONLY.

** THE SLOPE OF THE BOTTOM OF THE CURB AND GUTTER SHOULD MATCH THE SUPERELEVATION OF THE ROADWAY.

CONCRETE CURBS

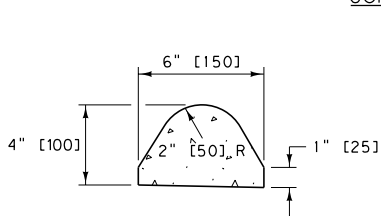

CURB SECTION

1 CUBIC FOOT OF CONCRETE WILL MAKE ABOUT 8 LINEAR FEET OF CURB. *
[1 CUBIC METER OF CONCRETE WILL MAKE ABOUT 89 METERS OF CURB]

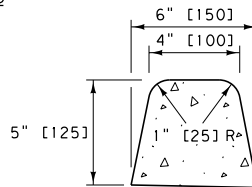

CURB SECTION

1 CUBIC FOOT OF CONCRETE WILL MAKE ABOUT 5 LINEAR FEET OF CURB. *
[1 CUBIC METER OF CONCRETE WILL MAKE ABOUT 64 METERS OF CURB]

NOTES:

- ① WHEN CURB IS USED IN CONJUNCTION WITH GUARDRAIL, USE THE 4" [100] HIGH TYPE. OTHERWISE, THE CONTRACTOR MAY USE EITHER SECTION.
- ② CONFORM ALL MATERIALS AND CONSTRUCTION PER SECTION 609.
- ③ PROVIDE CONTRACTION JOINTS IN CONCRETE CURBS AS DESCRIBED IN NOTE (B) ABOVE.

UNITS SHOWN IN BRACKETS [] ARE METRIC AND ARE IN MILLIMETERS (mm) UNLESS OTHER UNITS ARE SHOWN.

DETAILED DRAWING	
REFERENCE STANDARD SPEC. SECTION 609, 707	DWG. NO. 609-05
MISCELLANEOUS CURBS	
EFFECTIVE: SEPTEMBER 2014	
MDT MONTANA DEPARTMENT OF TRANSPORTATION	

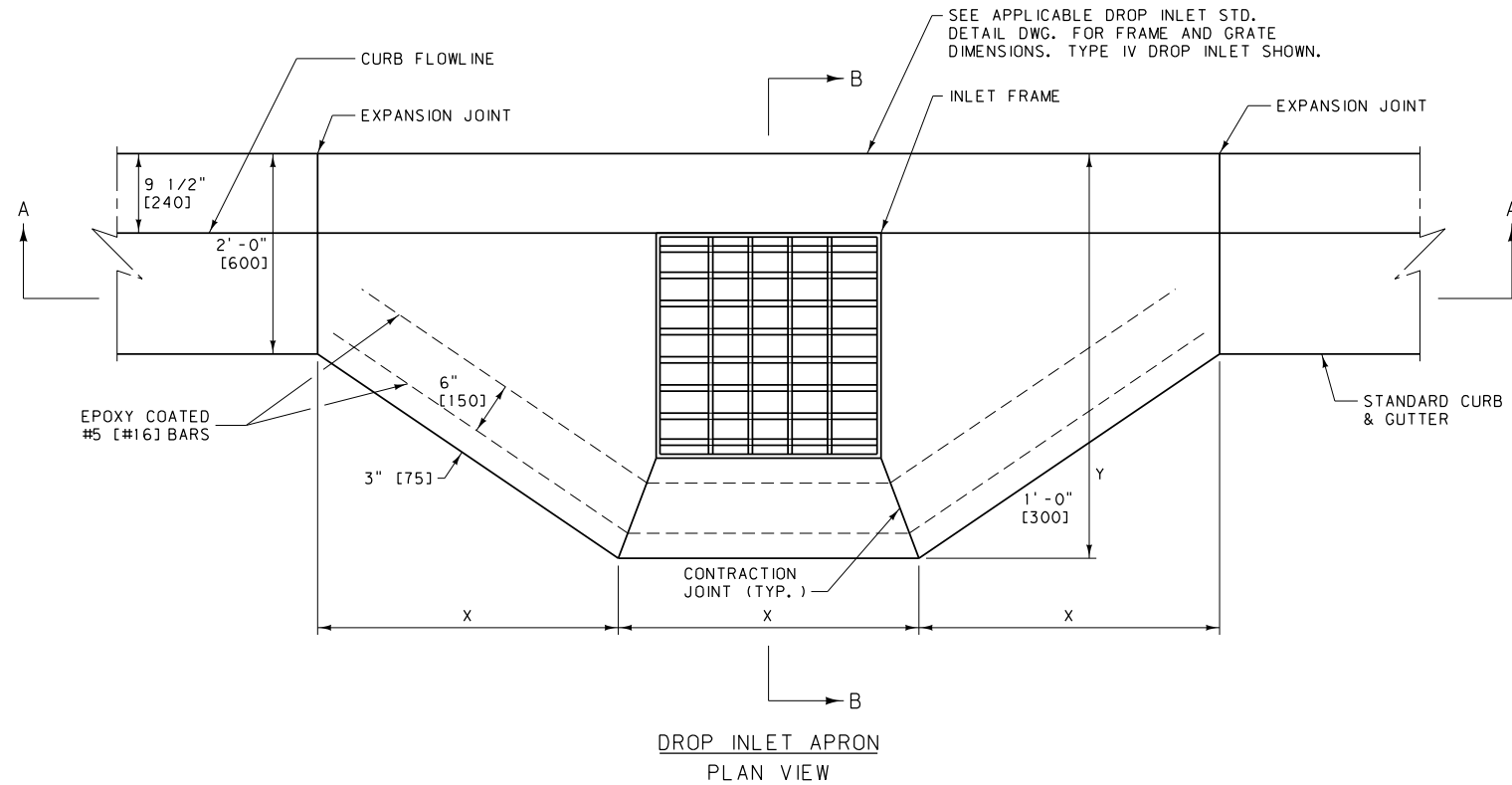

INLET TYPE		LENGTH	
		FT	mm
TYPE IV	X	3'-0"	925
	Y	3'-11 1/2"	1200
TYPE I, III, V, VI	X	3'-7"	1100
	Y	4'-6 7/8"	1400

DROP INLET TYPE I, III, V, VI			
ROADWAY % CROSS SLOPE*	APRON ELEV. BELOW TOP BACK OF CURB		GRATE & APRON SLOPE %
	FT	m	
0	0.45	0.137	3.31
0.5	0.44	0.134	3.63
1.0	0.43	0.131	3.96
1.5	0.41	0.125	4.28
2.0	0.40	0.122	4.60
2.5	0.39	0.119	4.93
3.0	0.37	0.113	5.25
3.5	0.36	0.110	5.57
4.0	0.35	0.107	5.90
4.5	0.34	0.104	6.22

* SEE CROSS SECTIONS FOR CROSS SLOPES ON STREET.

DROP INLET TYPE IV			
ROADWAY % CROSS SLOPE*	APRON ELEV. BELOW TOP BACK OF CURB		GRATE & APRON SLOPE %
	FT	m	
0	0.45	0.137	4.07
0.5	0.44	0.134	4.38
1.0	0.43	0.131	4.68
1.5	0.42	0.128	5.00
2.0	0.41	0.125	5.29
2.5	0.40	0.122	5.59
3.0	0.39	0.119	5.90
3.5	0.38	0.116	6.20
4.0	0.37	0.113	6.50
4.5	0.36	0.110	6.81

* SEE CROSS SECTIONS FOR CROSS SLOPES ON STREET.

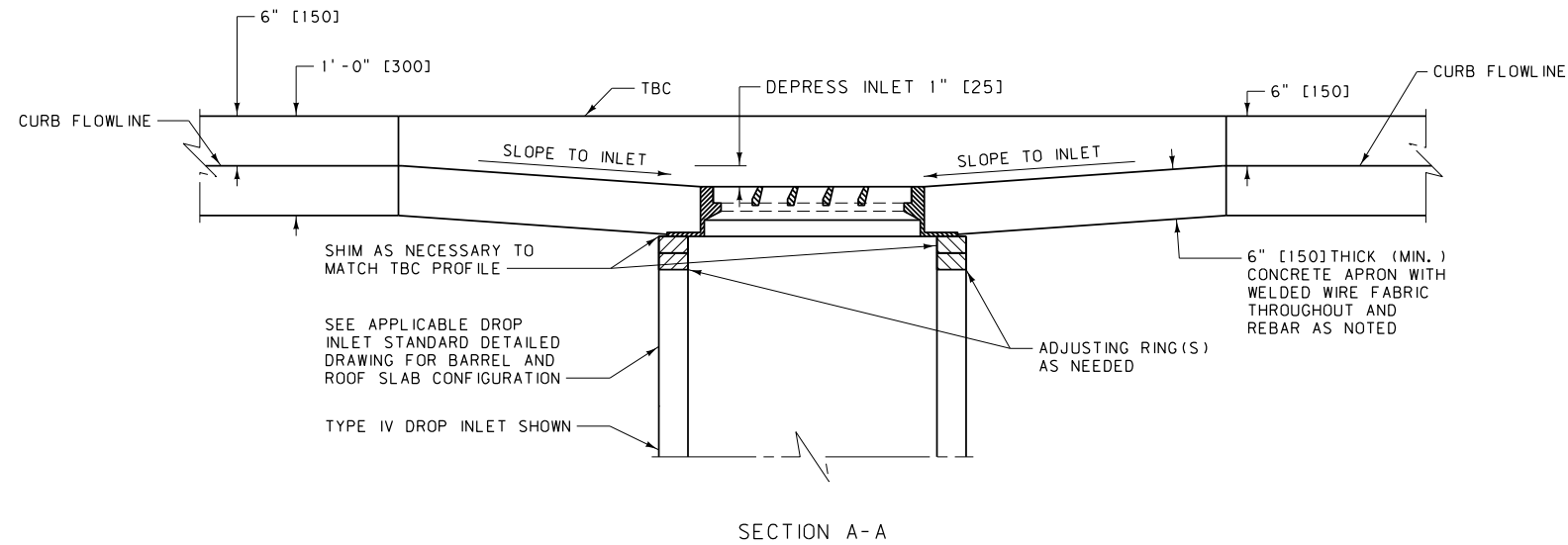

NOTES:

ALL CONCRETE IS CLASS GENERAL OR APPROVED EQUAL.

SHIM DROP INLET FRAME TO MATCH TBC PROFILE AND GRATE APRON SLOPE SHOWN IN THE TABLES. FILL SPACE BETWEEN GRATE AND ADJUSTING RING WITH CLASS GENERAL CONCRETE.

THE REFERENCED GRATE ELEVATION IS 1" LOWER THAN THE CURB FLOWLINE ELEVATION.

THE COST OF THE DROP INLET APRON IS INCLUDED IN THE UNIT PRICE BID FOR THE DROP INLET.

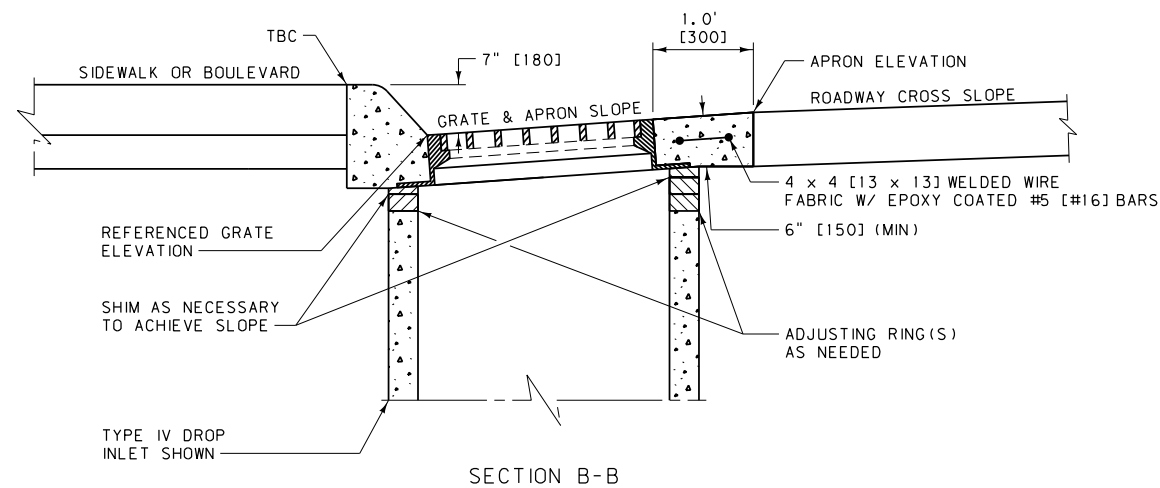

UNITS SHOWN IN BRACKETS [] ARE METRIC AND ARE IN MILLIMETERS (mm) UNLESS OTHER UNITS ARE SHOWN.

DETAILED DRAWING	
REFERENCE STANDARD SPEC. SECTION 609	DWG. NO. 609-07

DROP INLET APRONS

--REVISED-- JULY 2016	EFFECTIVE: SEPTEMBER 2014
MDT MONTANA DEPARTMENT OF TRANSPORTATION	

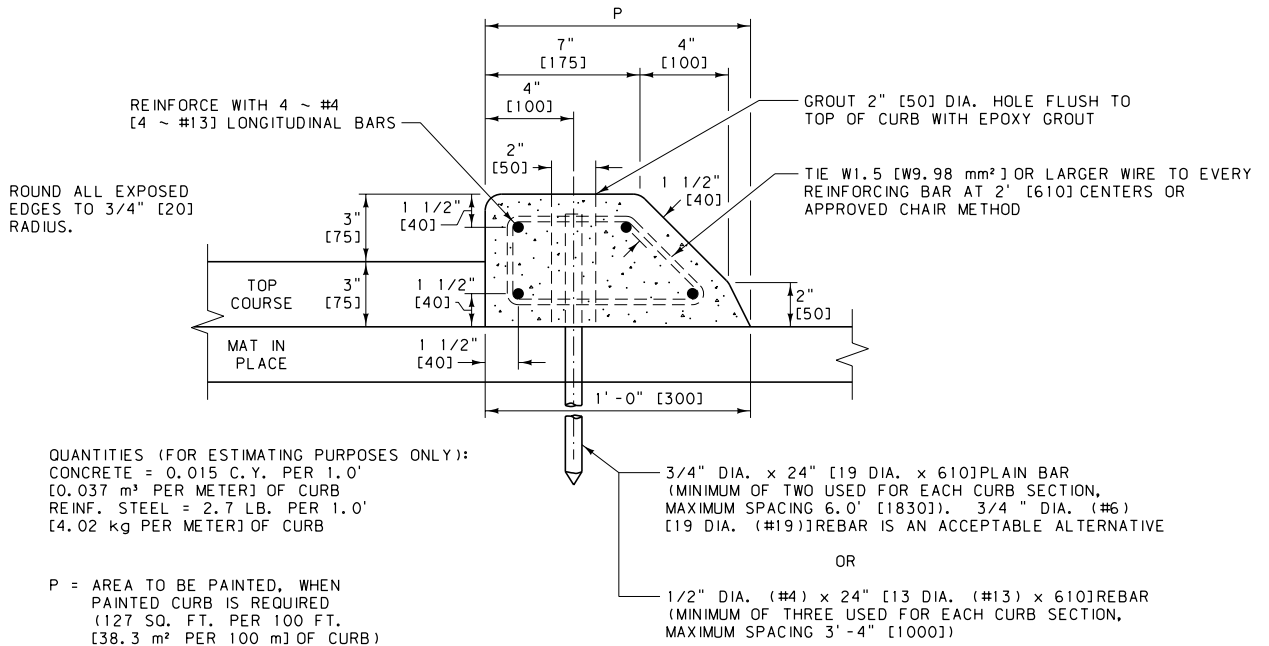

TYPE "A" - MAT IN PLACE

CONSTRUCTION:

1. CURBS MAY BE CONSTRUCTED USING ANY OF THE FOLLOWING THREE METHODS:
 - (1) PRECAST
 - (2) CAST IN PLACE
 - (3) CONSTRUCTED BY THE USE OF AN APPROVED CURB FORMING OR SLIP FORM MACHINE.
2. WHEN USING EITHER METHOD (2) OR (3), REINFORCING STEEL IS NOT REQUIRED, WITH THE EXCEPTION OF THE PINS. SCORE OR SAW CUT CURBS TO A DEPTH OF 1" [25] TO FORM CONTRACTION JOINTS AT INTERVALS OF 10 FT. [3000] OR LESS. EXTEND 1/2" [13] MIN. WIDTH EXPANSION JOINTS COMPLETELY THROUGH CURB EVERY 100 FT. (± 30 FT.) [30 m (± 10 m)], AT INTERVALS EQUAL TO THE NEAREST MULTIPLE OF THE CONTRACTION JOINT INTERVAL AND FILL WITH PERFORMED EXPANSION JOINT FILLER MEETING SECTION 707.
3. FORM PRECAST CURBS IN THEIR INVERTED POSITION, IN LENGTHS NOT LESS THAN 4 FT. [1220], OR MORE THAN 10 FT. [3050].

MATERIAL:

1. CONSTRUCT CURBS WITH CLASS GENERAL CONCRETE OR AN APPROVED EQUIVALENT MIX.
2. EPOXY BINDER FOR GROUTING MUST MEET THE REQUIREMENTS OF (AASHTO M 235 [235 M]) (ASTM C 881 [881 M]).

UNITS SHOWN IN BRACKETS [] ARE METRIC AND ARE IN MILLIMETERS (mm) UNLESS OTHER UNITS ARE SHOWN.

DETAILED DRAWING	
REFERENCE STANDARD SPEC. SECTION 609, 707	DWG. NO. 609-10
MEDIAN CONCRETE CURBS	
EFFECTIVE: SEPTEMBER 2014	
 MONTANA DEPARTMENT OF TRANSPORTATION	

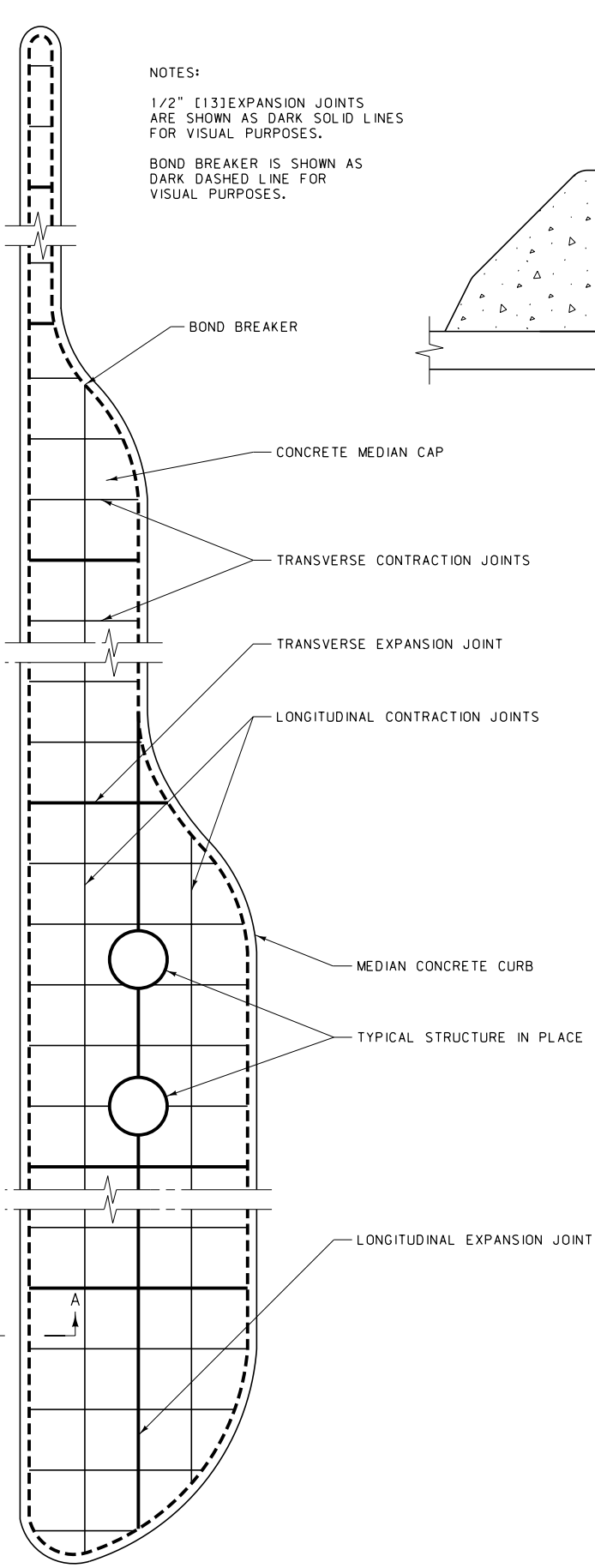

NOTES:
 1/2" [13] EXPANSION JOINTS ARE SHOWN AS DARK SOLID LINES FOR VISUAL PURPOSES.
 BOND BREAKER IS SHOWN AS DARK DASHED LINE FOR VISUAL PURPOSES.

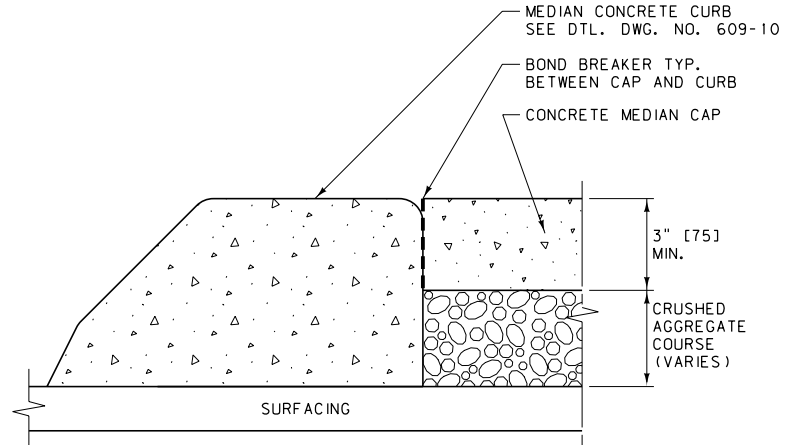

SECTION A-A

NOTES:

- ① INSTALL PREFORMED EXPANSION JOINT FILLER, PER SECTION 707, AT ALL EXPANSION JOINTS, FOR THE FULL THICKNESS OF THE CONCRETE MEDIAN CAP.
- ② INSTALL A BOND BREAKER FOR THE FULL THICKNESS OF THE CONCRETE MEDIAN CAP BETWEEN THE CAP AND THE CURB. USE A 15 OR 30 POUND [6.8 OR 13.6 kg] ROOFING FELT MATERIAL, OR OTHER PRODUCT AS APPROVED BY THE PROJECT MANAGER, FOR THE BOND BREAKER. DO NOT USE EXPANSION JOINT MATERIAL AS A BOND BREAKER.
- ③ ALL JOINTS MUST BE STRAIGHT AND PERPENDICULAR TO THE CENTERLINE AND THE SURFACE OF THE MEDIAN CAP. WHERE PRACTICAL, ALIGN ALL JOINTS WITH LIKE JOINTS IN ADJOINING WORK. USE JOINTS TO OUTLINE ALL PANELS IN THE MEDIAN CAP. USE SQUARE PANELS WHEN PRACTICAL. ON NARROW MEDIAN CAPS RECTANGULAR SHAPED PANELS ARE ACCEPTABLE.
- ④ PROVIDE CONTRACTION JOINTS NO LESS THAN 1/8" [3] WIDE AND NO MORE THAN 1/4" [6] WIDE AND NO LESS THAN 1" [25] IN DEPTH. CONTRACTION JOINTS MAY BE CUT BY A GROOVE FORMING TOOL.
- ⑤ LOCATE EXPANSION JOINTS AT ALL JOINTS BETWEEN THE MEDIAN CAP AND STRUCTURES IN PLACE AND EVERY 100 FT. (+30 FT.) [30 m (+10 m)] AT INTERVALS EQUAL TO THE NEAREST MULTIPLE OF THE CONTRACTION JOINT INTERVAL. USE A LONGITUDINAL EXPANSION JOINT IN THE CENTERLINE OF ALL MEDIAN CAPS WIDER THAN 12 FT. [3660].
- ⑥ USE LONGITUDINAL CONTRACTION JOINTS IN MEDIAN CAPS WIDER THAN 6 FT. [1830], WITH SPACING NOT TO EXCEED 6 FT. [1830]. SPACE TRANSVERSE CONTRACTION JOINTS EQUAL TO THE LONGITUDINAL SPACING ON MEDIAN CAPS WIDER THAN 6 FT. [1830]. FOR MEDIAN CAPS NARROWER THAN 6 FT. [1830], SPACE TRANSVERSE CONTRACTION JOINTS 10 FT. [3000] OR LESS.
- ⑦ CONSTRUCT CONCRETE MEDIAN CURB AND CAP WITH CLASS GENERAL CONCRETE OR APPROVED EQUAL.

UNITS SHOWN IN BRACKETS [] ARE METRIC AND ARE IN MILLIMETERS (mm) UNLESS OTHER UNITS ARE SHOWN.

DETAILED DRAWING	
REFERENCE STANDARD SPEC.	DWG. NO. 609-12
CONCRETE MEDIAN CAPS	
EFFECTIVE: SEPTEMBER 2014	
MONTANA DEPARTMENT OF TRANSPORTATION	