

PLAN
(INTERSTATE LAYOUT SHOWN)

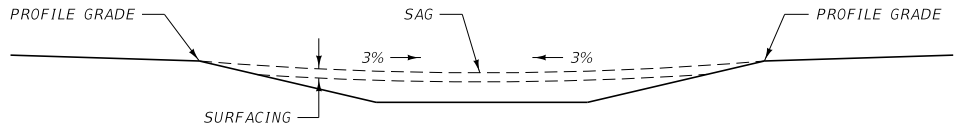

PROFILE

MEDIAN WIDTHS 36' [10.8 m] TO 76' [22.8 m]

LOCATE AND CONSTRUCT TURNOUTS ABOVE IN CONJUNCTION WITH DITCH BLOCKS IF AT ALL POSSIBLE. PROVIDE DRAINAGE WHEN NECESSARY.

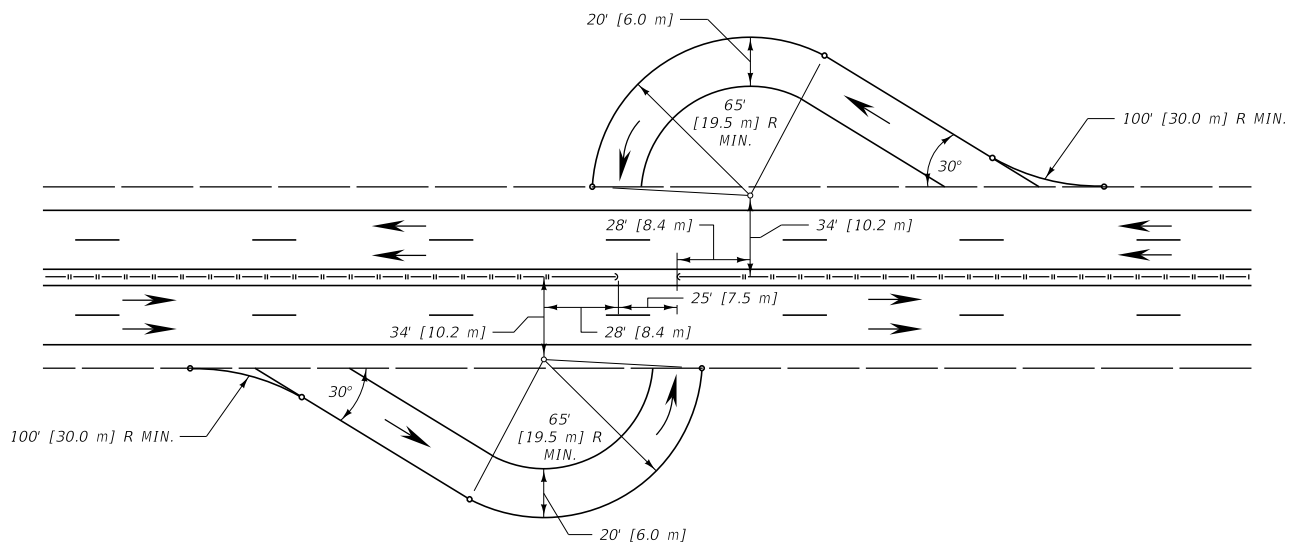

STANDARD U-TURN FOR NARROW MEDIANS

NOTES:

- ① NARROW MEDIANS, MEDIAN WIDTHS GREATER THAN 76' [22.8 m] AND INDEPENDENT ROADWAYS REQUIRE SPECIAL DESIGN.
- ② GRADES: UNIFORM BETWEEN INSIDE SHOULDERS OF MAIN TRAVELED WAY EXCEPT FOR SPECIAL DESIGN.
- ③ SURFACING: SEE PLANS FOR QUANTITIES.
- ④ DRAINAGE: USE 18" [450] OR 24" [600] CULVERTS IF REQUIRED.

UNITS SHOWN IN BRACKETS [] ARE METRIC AND ARE IN MILLIMETERS (mm) UNLESS OTHER UNITS ARE SHOWN.

DETAILED DRAWING	
REFERENCE SECTION	DWG. NO. 900-00
U-TURN MEDIAN OPENINGS ON CONTROLLED ACCESS HIGHWAYS	
EFFECTIVE: SEPTEMBER 2014	
MDT MONTANA DEPARTMENT OF TRANSPORTATION	

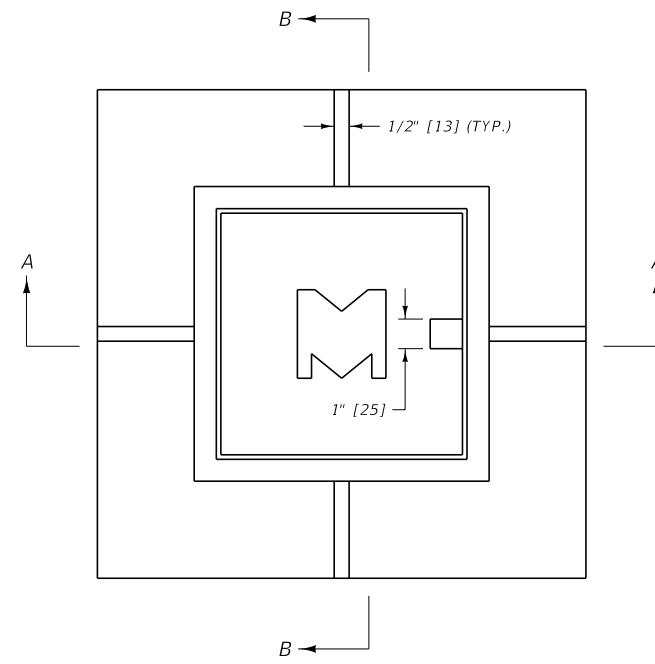
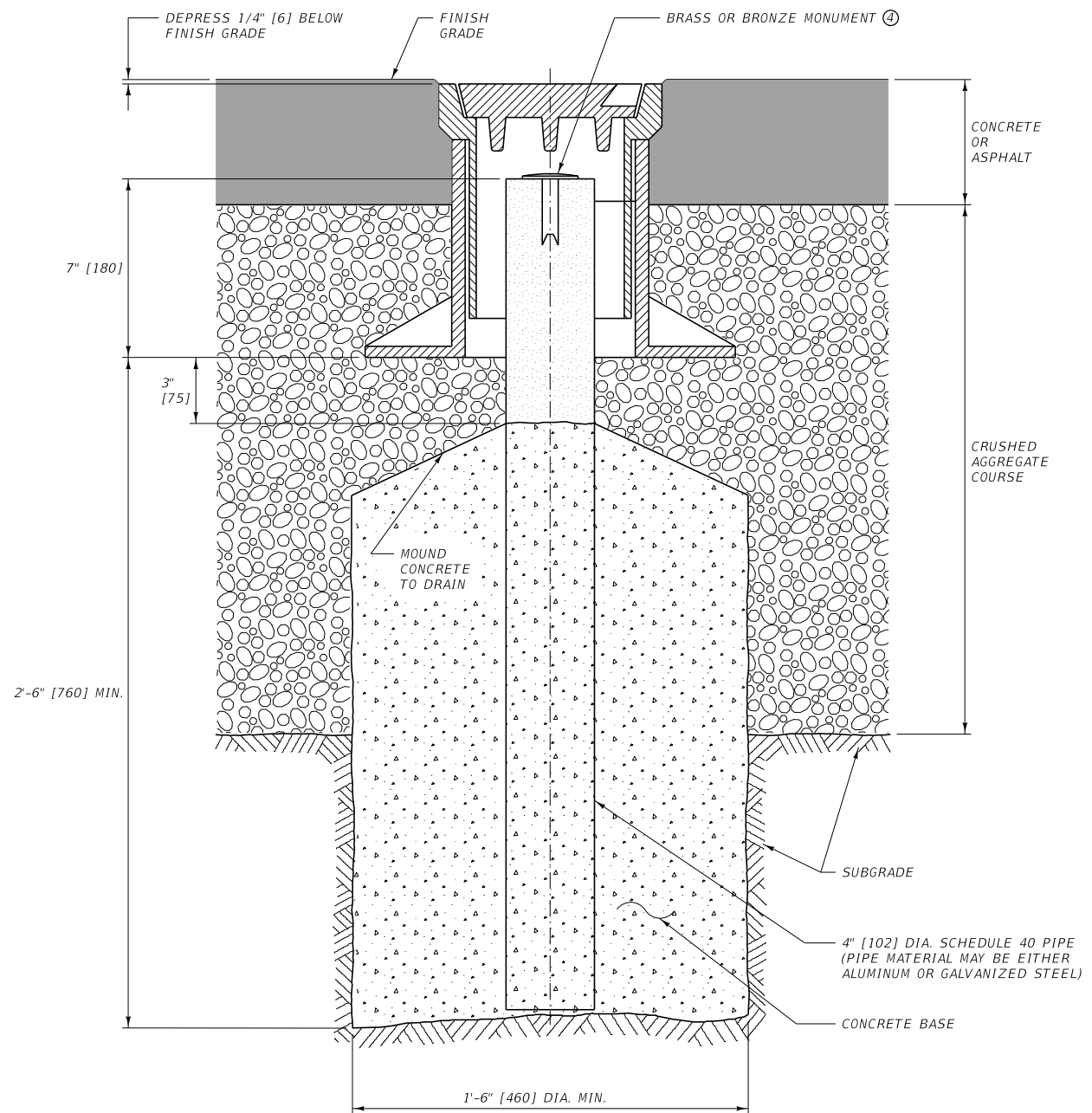

PLAN
NEENAH FOUNDRY R-1968 TYPE 36-B ADJUSTABLE
MONUMENT BOX (HEAVY DUTY) OR APPROVED EQUAL

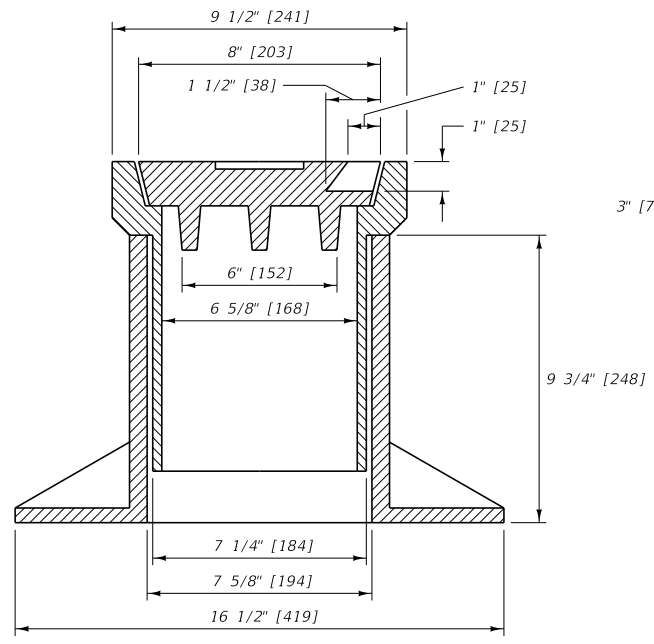

SECTION A-A

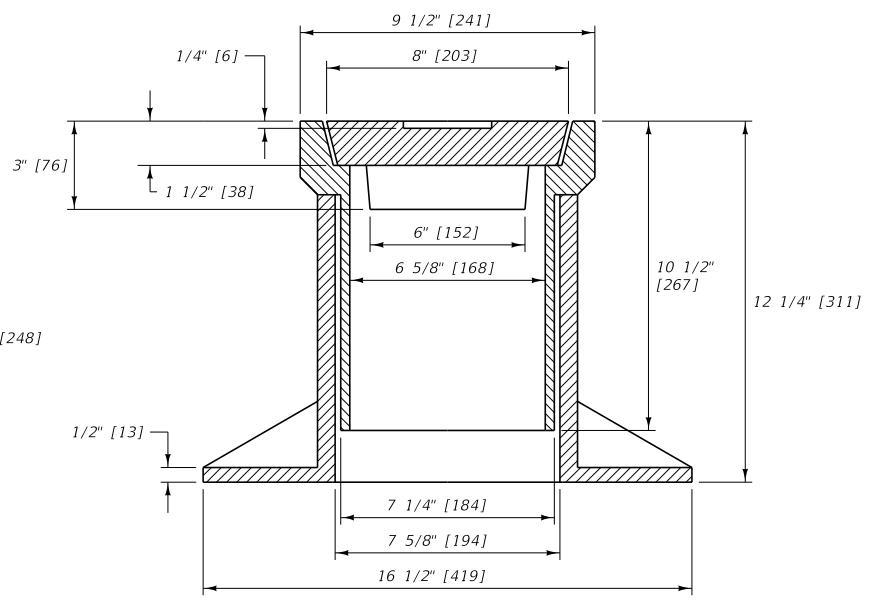

SECTION B-B

NOTES:

- ① INSTALL THE 4" [102] DIA. PIPE, CONCRETE BASE AND ADJUSTABLE MONUMENT BOX AS DETAILED. PLACE CONCRETE IN THE PIPE UP TO 10" [255] BELOW THE TOP OF THE PIPE (DO NOT FILL COMPLETELY.)
- ② POSITION THE CENTER OF THE PIPE TO WITHIN 1/2" [13] HORIZONTALLY OF THE DESIRED COORDINATES AND CENTER THE MONUMENT BOX OVER THE PIPE.
- ③ DEPENDING ON CONTRACT REQUIREMENTS, EITHER MDT FORCES UNDER THE DIRECT SUPERVISION OF A MONTANA LICENSED PROFESSIONAL LAND SURVEYOR OR CONTRACTOR FORCES UNDER THE DIRECT SUPERVISION OF A MONTANA LICENSED PROFESSIONAL LAND SURVEYOR IS REQUIRED TO FILL THE REMAINING 10" [255] OF THE 4" [102] DIA. PIPE WITH CONCRETE. SET AND MARK THE BRASS OR BRONZE MONUMENT WITHIN THE BOX AFTER CONSTRUCTION. THE MONTANA LICENSED PROFESSIONAL LAND SURVEYOR IS REQUIRED TO PREPARE AND FILE CORNER RECORDATIONS IN ACCORDANCE WITH STATE STATUTES, ADMINISTRATIVE RULES OF MONTANA AND PROVISIONS OF THE MDT SURVEY MANUAL. PROVIDE COPIES OF FILED CORNER RECORDATIONS TO THE PROJECT MANAGER, WHO WILL FORWARD THEM TO THE DISTRICT SURVEY MANAGER.
- ④ AN ACCEPTABLE BRONZE MONUMENT IS THE "BERNTSEN C25DB" OR APPROVED EQUAL. AN ACCEPTABLE BRASS MONUMENT IS THE "SURV-KAP M/M-BCS-2 1/2 D" OR APPROVED EQUAL.
- ⑤ USE CLASS GENERAL CONCRETE OR APPROVED EQUAL.

UNITS SHOWN IN BRACKETS [] ARE METRIC AND ARE IN MILLIMETERS (mm) UNLESS OTHER UNITS ARE SHOWN.

DETAILED DRAWING	
REFERENCE STANDARD SPEC. SECTION	DWG. NO. 900-15
ADJUSTABLE MONUMENT BOX	
---REVISED--- JULY 2016	EFFECTIVE: SEPTEMBER 2014
MONTANA DEPARTMENT OF TRANSPORTATION	