

END VIEW

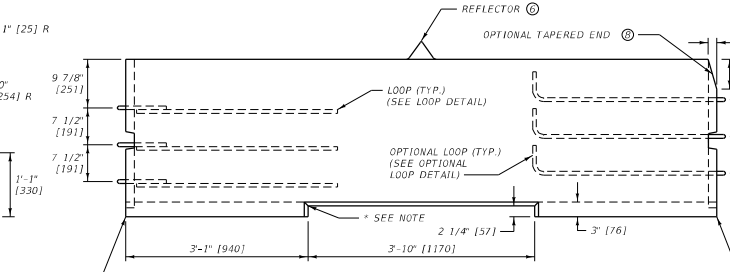

ELEVATION VIEW

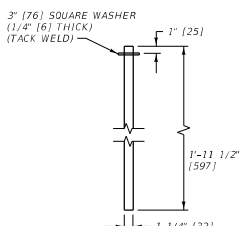

CONNECTING PIN DETAIL

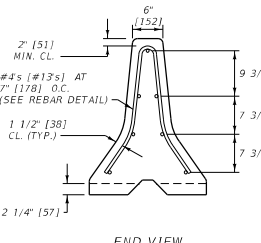

END VIEW

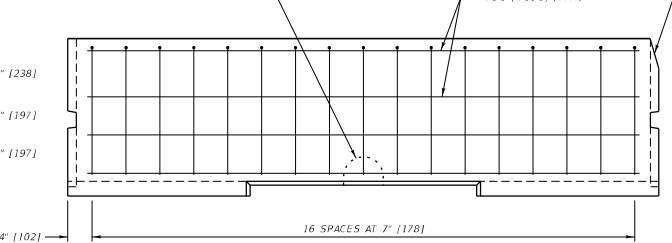

PLAN VIEW

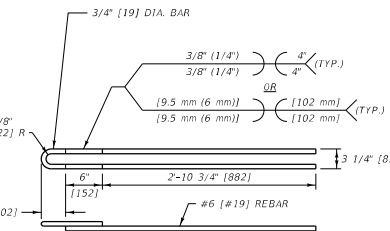

LOOP DETAIL

- LOOP FABRICATION REQUIREMENTS:**
- USE REINFORCING STEEL CONFORMING TO ASTM A 706 (706M), GRADE 60 (420) FOR REBAR BEING WELDED TO LOOPS.
 - LOOP ENDS CONSIST OF SMOOTH ROUND BARS CONFORMING TO AASHTO M 270 (270M), GRADE 36 (250).
 - COLD BEND THE LOOPS BY USING A JIG THAT WILL PRODUCE AN ACCURATE RADIUS WITHOUT WARRING THE BAR. DO NOT HEAT THE BAR TO FACILITATE BENDING.
 - WELD REBAR TO LOOPS MEETING SECTION 624 REQUIREMENTS USING 1/8" (3 mm) DIA. E8018 ROD. DO NOT TACK WELD THE PIECES TOGETHER PRIOR TO WELDING.
 - NO ADDITIONAL WELDING IS PERMITTED ON THE SMOOTH ROUND BARS OR REINFORCING STEEL.

- OPTIONAL LOOP FABRICATION REQUIREMENTS:**
- USE CONTINUOUS SMOOTH ROUND BARS CONFORMING TO AASHTO M 270 (270M), GRADE 36 (250) TO FABRICATE THE OPTIONAL LOOPS.
 - COLD BEND THE LOOPS BY USING A JIG THAT WILL PRODUCE AN ACCURATE RADIUS WITHOUT WARRING THE BAR. DO NOT HEAT THE BAR TO FACILITATE BENDING.
 - NO WELDING IS PERMITTED ON THE SMOOTH ROUND BARS OR REINFORCING STEEL.

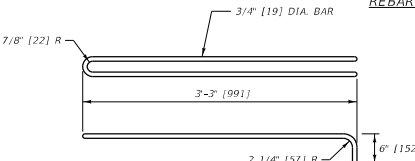

OPTIONAL LOOP DETAIL

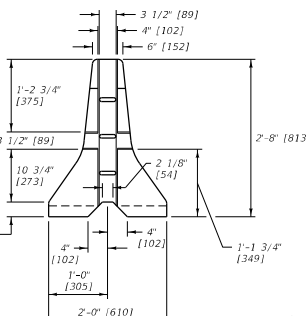

END VIEW

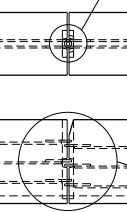

ALTERNATE CONCRETE BARRIER RAIL DETAIL

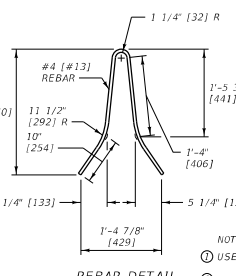

REBAR DETAIL

MINIMUM REFLECTIVE SHEETING, WHITE OR YELLOW PER MUTCD

- NOTES:**
- USE CLASS DECK CONCRETE OR EQUIVALENT.
 - REINFORCING STEEL CONSISTS OF DEFORMED BARS CONFORMING TO AASHTO M 31 (31M), GRADE 60 (420).
 - CONNECT EACH 10' (3.05 m) SECTION WITH CONNECTING PINS AS DETAILED AND CONFORMING TO AASHTO M 270 (270M), GRADE 36 (250) OR BETTER. CONNECTING PINS NEED NOT BE PAINTED.
 - CUTOUPS ON ENDS OF EACH SECTION ARE SHOWN WITH SLIGHT TAPER TO FACILITATE FORM REMOVAL. RECTANGULAR CUTOUPS ARE ACCEPTABLE.
 - THE CONTRACTOR IS RESPONSIBLE FOR THE PROPER FIT-UP OF THE PRECAST CONCRETE BARRIER RAIL ASSEMBLY AND PIN SUFFICIENT NUMBER OF PRECAST SECTIONS IN THE FABRICATIONS PLANT TO DETERMINE THAT PROPER FIT-UP CAN BE MAINTAINED ON ALL ROADWAY ALIGNMENT, CURVES AS WELL AS ON TANGENT. THIS IS TO BE DETERMINED EARLY IN FABRICATION.
 - ATTACH REFLECTORS TO RAIL EVERY 30' (9.15 m). USE ALUMINUM ALLOY MEETING THE ALUMINUM ASSOCIATION ALLOY A4052-H32. FOLLOW THE MANUFACTURER'S SPECIFICATIONS FOR ADHESIVE MOUNTING IN NARROW PAVED (FLUSH) MEDIAN APPLICATIONS. REFLECTORIZE BOTH SIDES.
 - DO NOT INSTALL UNANCHORED CONCRETE BARRIER RAIL FOR OBSTACLES WITHIN 6.5 (2.1 m) OF THE BASE (TRAFFIC SIDE) OF THE RAIL. SEE DTL. DWN NO. 605-05 FOR CONCRETE BARRIER RAIL ANCHORS.
 - THE OPTIONAL TAPERED END SHOWN IS AN ACCEPTABLE ALTERNATE TO THE VERTICAL END FOR ALL CONCRETE BARRIER RAIL ENDS.
 - GALVANIZE OR EPOXY COAT LOOPS AND CONNECTING PINS AFTER FABRICATION/BENDING. EPOXY COAT IN ACCORDANCE WITH SUBSECTION 711.02.1. GALVANIZE IN ACCORDANCE WITH ASTM A153, B695 (CLASS 50) OR OTHER APPLICABLE ASTM GALVANIZING STANDARDS.

1 1/4" [32] DIA. PIN W/ 3" [76] SQUARE WASHER (SEE DETAIL)

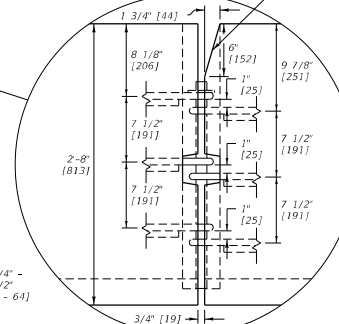

OPTIONAL TAPERED END

3/4" [19 mm] CHAMFER ENTIRE OPENING FOR SUFFICIENTLY ROUNDED SO THAT A SMOOTH EDGE RESULTS. 1/2" [13 mm] CHAMFER IS ACCEPTABLE.
* USE THE ALTERNATE 8" (200 mm) DIA. HOLE IN THIS RAIL ON A CASE-BY-CASE BASIS AS SPECIFIED IN THE PLANS.

UNITS SHOWN IN BRACKETS [] ARE METRIC AND ARE IN MILLIMETERS (mm) UNLESS OTHER UNITS ARE SHOWN.

DETAILED DRAWING	
REFERENCE STANDARD SPEC. SECTION 354.605.624.711	DWG. NO. 605-00
CONCRETE BARRIER RAIL	
MDT MONTANA DEPARTMENT OF TRANSPORTATION	

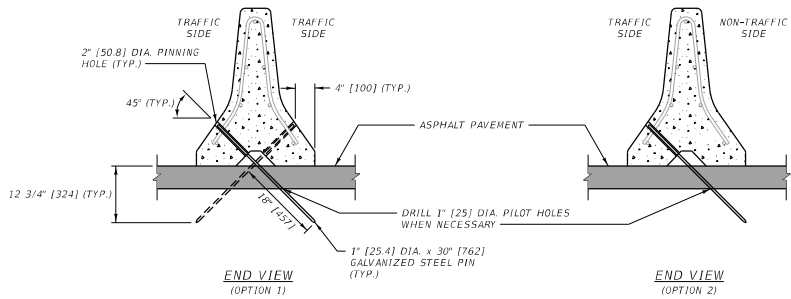

TYPE 1 ANCHOR
(FOR TEMPORARY OR PERMANENT CONCRETE BARRIER RAIL INSTALLATIONS ON ASPHALT PAVEMENT)

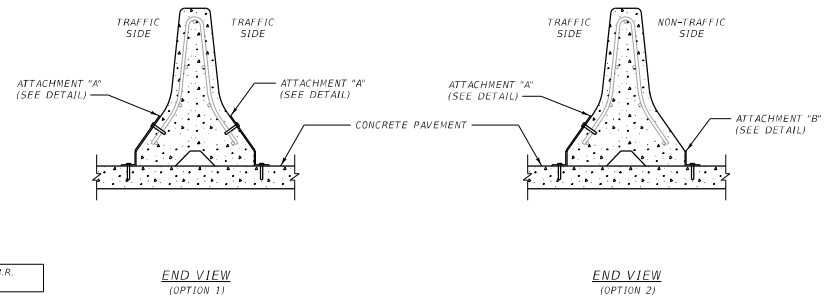

TYPE 2 & 3 ANCHORS
(FOR TEMPORARY CONCRETE BARRIER RAIL INSTALLATIONS ON CONCRETE PAVEMENT)

OPTION 1 = TRAFFIC ON BOTH SIDES OF C.B.R.
OPTION 2 = TRAFFIC ON ONE SIDE OF C.B.R.

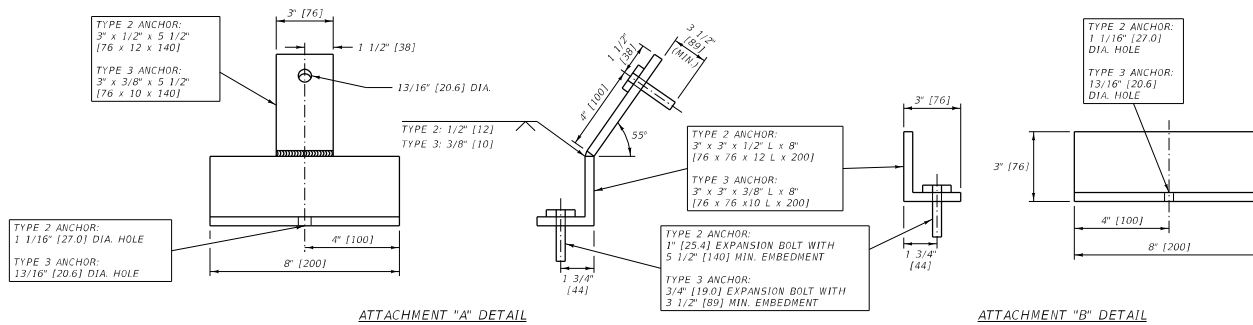
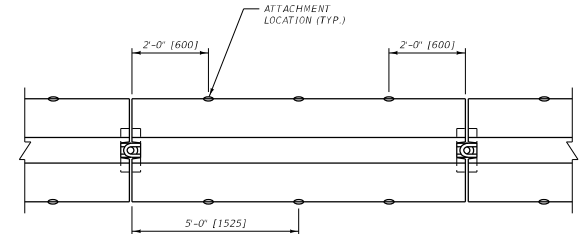
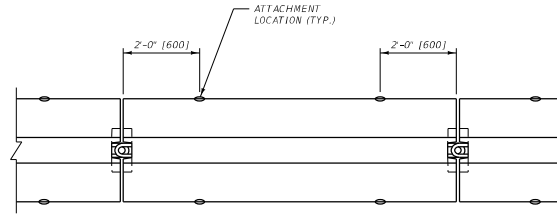
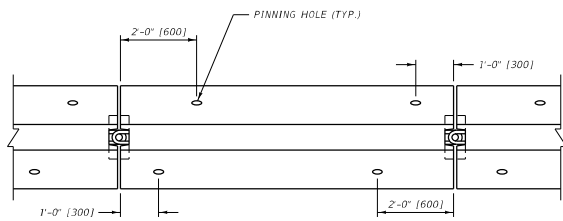

- NOTES:**
- USE THESE ANCHORS WITH STANDARD CONCRETE BARRIER RAIL (C.B.R.), AS SHOWN IN DTL. DWG. NO. 605-00, WHEN DEFLECTION OF THE SYSTEM NEEDS TO BE LIMITED.
 - CAST THE PINNING HOLES INTO THE C.B.R. USING 2" [50.8] I.D. STEEL PIPE. DO NOT DRILL THE PINNING HOLES.
 - USE STEEL CONFORMING TO AASHTO M 270 [270M], GRADE 36 [250] OR BETTER FOR PINS AND ATTACHMENT ANGLE. GALVANIZE IN ACCORDANCE WITH SUBSECTION 711.08.
 - USE TYPE 2 ANCHORS WHEN A DEEPER EMBEDMENT (5 1/2" [140]) INTO THE BRIDGE DECK OR CONCRETE PAVEMENT IS PERMISSIBLE.
 - ADJUST THE LOCATION OF THE TYPE 2 OR TYPE 3 ANCHORS TO AVOID THE MAIN REINFORCING WHEN PLACED ON BRIDGE DECK.
 - USE SHIMS TO PROPERLY FIT THE TYPE 2 AND TYPE 3 ANCHORS TO THE BARRIER AND ROADWAY SURFACES.
 - AFTER REMOVING TYPE 2 OR TYPE 3 ANCHORS, CLEAN THE HOLES IN THE CONCRETE PAVEMENT AND FILL WITH AN APPROVED NON-SHRINK OR EPOXY GROUT.
 - REMOVE TYPE 1 ANCHORS BY FIRST DRIVING THE STEEL PINS DOWN THROUGH THE BARRIER TO ALLOW LIFTING OF THE BARRIER WITHOUT INTERFERENCE. THEN REMOVE THE PINS FROM THE PAVEMENT AND FILL THE PINNING HOLES WITH AN APPROVED SEALANT.
 - DO NOT INSTALL ANCHORED CONCRETE BARRIER RAIL FOR OBSTACLES WITHIN 3.5 [11.1 m] OF THE BASE (TRAFFIC SIDE) OF THE RAIL.

UNITS SHOWN IN BRACKETS [] ARE METRIC AND ARE IN MILLIMETERS (mm) UNLESS OTHER UNITS ARE SHOWN.

DETAILED DRAWING	
REFERENCE	DWG. NO.
STANDARD SPEC.	605-05
SECTION	334.605

CONCRETE BARRIER RAIL ANCHORS

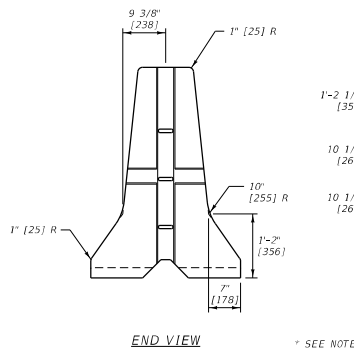

END VIEW

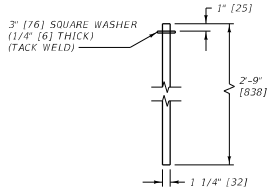

CONNECTING PIN DETAIL

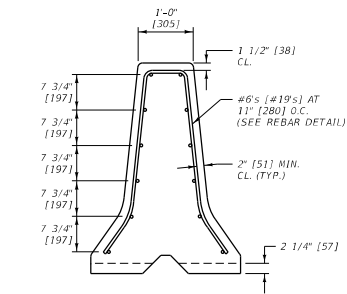

END VIEW

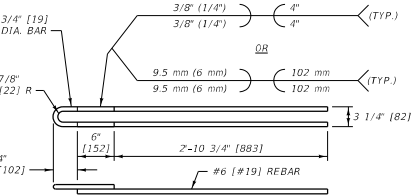

LOOP DETAIL

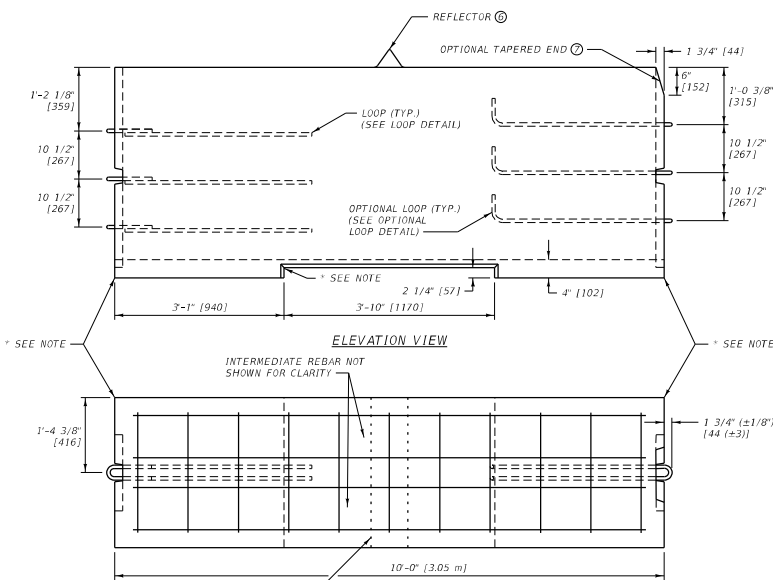

ELEVATION VIEW

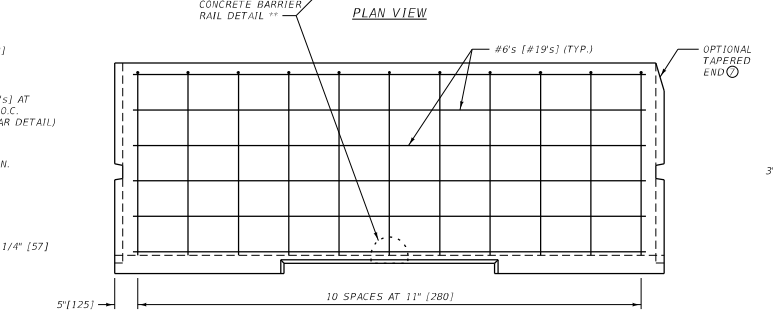

PLAN VIEW

LOOP FABRICATION REQUIREMENTS:

1. USE REINFORCING STEEL CONFORMING TO ASTM A 706 (706M), GRADE 60 (420) FOR REBAR BEING WELDED TO LOOPS.
2. LOOP ENDS CONSIST OF SMOOTH ROUND BARS CONFORMING TO AASHTO M 270 (270M), GRADE 36 (250).
3. COLD BEND THE LOOPS BY USING A JIG THAT WILL PRODUCE AN ACCURATE RADIUS WITHOUT MARRING THE BAR. DO NOT HEAT THE BAR TO FACILITATE BENDING.
4. WELD REBAR TO LOOPS MEETING SECTION 556 REQUIREMENTS USING 1/8\"/>

OPTIONAL LOOP FABRICATION REQUIREMENTS:

1. USE CONTINUOUS SMOOTH ROUND BARS CONFORMING TO AASHTO M 270 (270M), GRADE 36 (250) TO FABRICATE THE OPTIONAL LOOPS.
2. COLD BEND THE LOOPS BY USING A JIG THAT WILL PRODUCE AN ACCURATE RADIUS WITHOUT MARRING THE BAR. DO NOT HEAT THE BAR TO FACILITATE BENDING.
3. NO WELDING IS PERMITTED ON THE SMOOTH ROUND BARS OR REINFORCING STEEL.

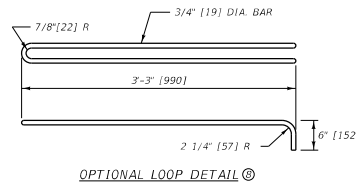

OPTIONAL LOOP DETAIL

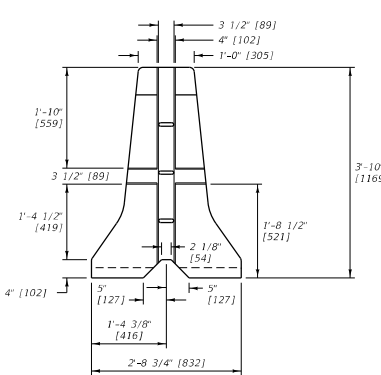

END VIEW

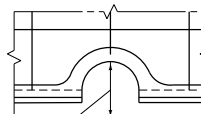

ALTERNATE TALL CONCRETE BARRIER RAIL DETAIL

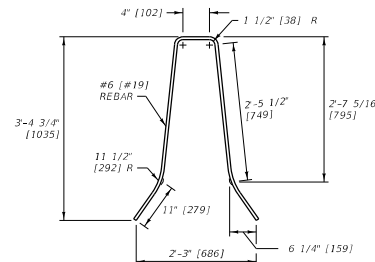

REBAR DETAIL

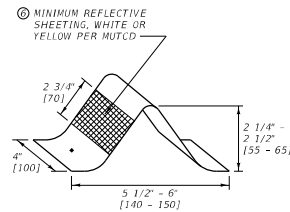

REFLECTOR (SEE NOTES)

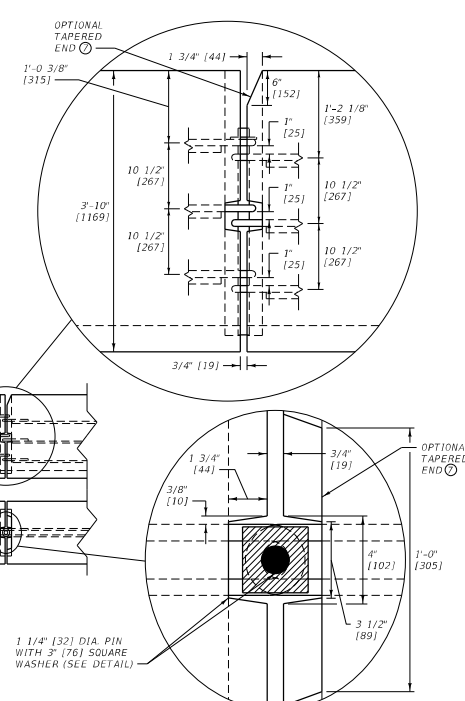

NOTES:

1. USE CLASS DECK CONCRETE OR EQUIVALENT.
2. REINFORCING STEEL CONSISTS OF DEFORMED BARS CONFORMING TO AASHTO M 31 (31M), GRADE 60 (420).
3. CONNECT EACH 10' (3.05 m) SECTION WITH CONNECTING PINS AS DETAILED AND CONFORMING TO AASHTO M 270 (270M), GRADE 36 (250) OR BETTER. CONNECTING PINS NEED NOT BE PAINTED.
4. CUTOUTS ON ENDS OF EACH SECTION ARE SHOWN WITH SLIGHT TAPER TO FACILITATE FORM REMOVAL. RECTANGULAR CUTOUTS ARE ACCEPTABLE.
5. THE CONTRACTOR IS RESPONSIBLE FOR THE PROPER FIT-UP OF THE PRECAST CONCRETE BARRIER RAIL ASSEMBLY AND PIN SUFFICIENT NUMBER OF PRECAST SECTIONS IN THE FABRICATIONS PLANT TO DETERMINE THAT PROPER FIT-UP CAN BE MAINTAINED ON ALL ROADWAY ALIGNMENT, CURVES AS WELL AS ON TANGENT. THIS IS TO BE DETERMINED EARLY IN FABRICATION.
6. ATTACH REFLECTORS TO RAIL EVERY 30' (9.15 m). USE ALUMINUM ALLOY MEETING THE ALUMINUM ASSOCIATION ALLOY AA5052-H32. FOLLOW THE MANUFACTURER'S SPECIFICATIONS FOR ADHESIVE MOUNTING. IN NARROW PAVED (FLUSH) MEDIAN APPLICATIONS, REFLECTORIZE BOTH SIDES.
7. THE OPTIONAL TAPERED END SHOWN IS AN ACCEPTABLE ALTERNATE TO THE VERTICAL END FOR ALL CONCRETE BARRIER RAIL ENDS.
8. GALVANIZE OR EPOXY COAT LOOPS AND CONNECTING PINS AFTER FABRICATION/ BENDING. EPOXY COAT IN ACCORDANCE WITH SUBSECTION 711.02.1. GALVANIZE IN ACCORDANCE WITH ASTM A153, B695 (CLASS 50) OR OTHER APPLICABLE ASTM GALVANIZING STANDARDS.
9. 3/4\"/>

UNITS SHOWN IN BRACKETS [] ARE METRIC AND ARE IN MILLIMETERS (mm) UNLESS OTHER UNITS ARE SHOWN.

DETAILED DRAWING	
REFERENCE STANDARD SPEC. SECTION 354-356,605,711	DWG. NO. 605-10

TALL CONCRETE BARRIER RAIL

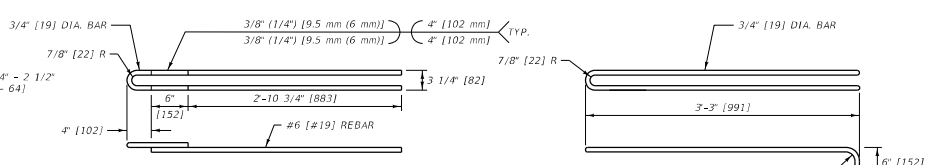
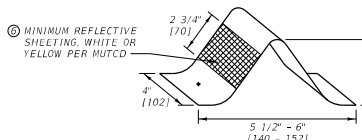

- LOOP FABRICATION REQUIREMENTS:**
1. USE REINFORCING STEEL CONFORMING TO ASTM A 706 [706M], GRADE 60 [420] FOR REBAR BEING WELDED TO LOOPS.
 2. LOOP ENDS CONSIST OF SMOOTH ROUND BARS CONFORMING TO AASHTO M 270 [270M], GRADE 36 [250].
 3. COLD BEND THE LOOPS BY USING A JIG THAT WILL PRODUCE AN ACCURATE RADIUS WITHOUT HARRING THE BAR. DO NOT HEAT THE BAR TO FACILITATE BENDING.
 4. WELD REBAR TO LOOPS MEETING SECTION 556 REQUIREMENTS USING 1/8" [3] DIA. E8018 ROD. DO NOT TACK WELD THE PIECES TOGETHER PRIOR TO WELDING.
 5. NO ADDITIONAL WELDING IS PERMITTED ON THE SMOOTH ROUND BARS OR REINFORCING STEEL.

- OPTIONAL LOOP FABRICATION REQUIREMENTS:**
1. USE CONTINUOUS SMOOTH ROUND BARS CONFORMING TO AASHTO M 270 [270M] GRADE 36 [250] TO FABRICATE THE OPTIONAL LOOPS.
 2. COLD BEND THE LOOPS BY USING A JIG THAT WILL PRODUCE AN ACCURATE RADIUS WITHOUT HARRING THE BAR. DO NOT HEAT THE BAR TO FACILITATE BENDING.
 3. NO ADDITIONAL WELDING IS PERMITTED ON THE SMOOTH ROUND BARS OR REINFORCING STEEL.

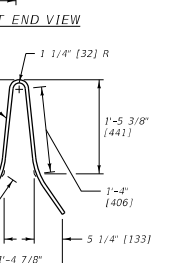
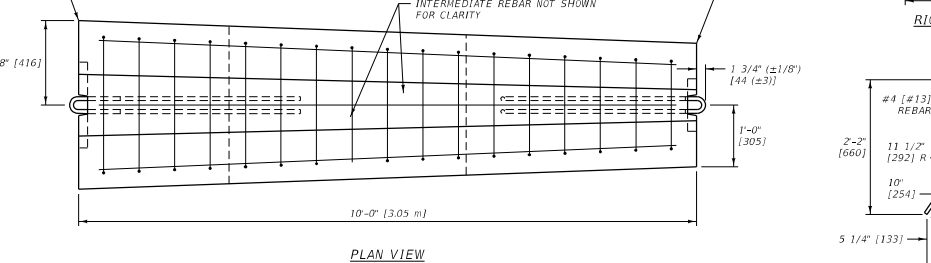
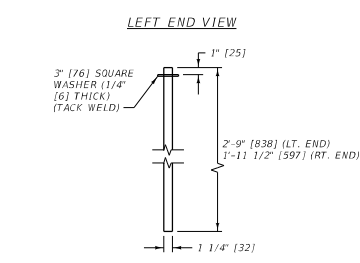
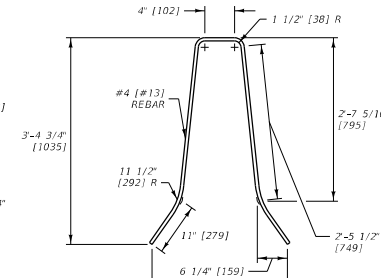
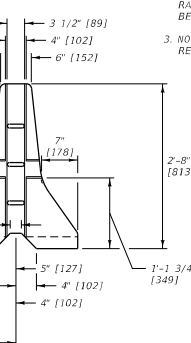
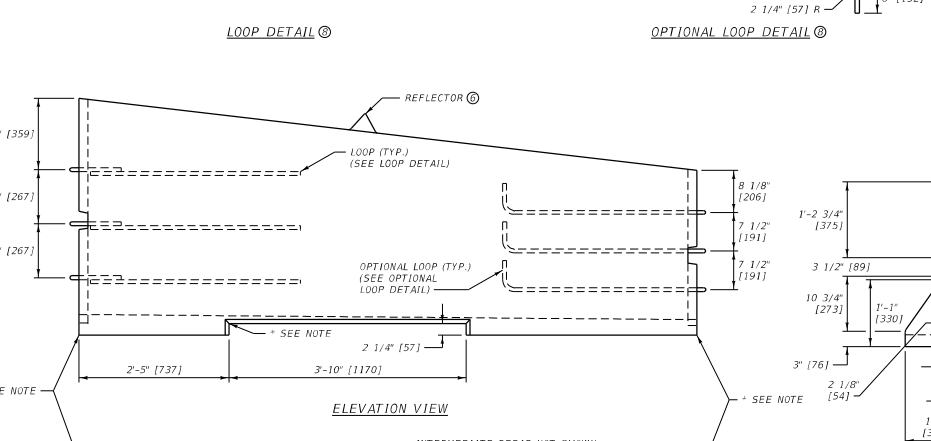
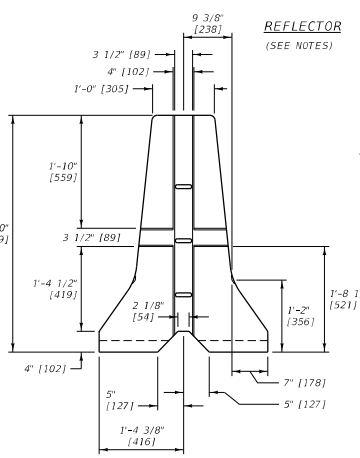

- NOTES:**
1. USE CLASS DECK CONCRETE OR EQUIVALENT.
 2. REINFORCING STEEL CONSISTS OF DEFORMED BARS CONFORMING TO AASHTO M 31 [31M], GRADE 60 [420].
 3. CONNECT EACH 10' SECTION WITH CONNECTING PINS AS DETAILED AND CONFORMING TO AASHTO M 270 [270M], GRADE 36 [250] OR BETTER. CONNECTING PINS SHOULD NOT BE PAINTED.
 4. CUTOUTS ON ENDS OF EACH SECTION ARE SHOWN WITH SLIGHT TAPER TO FACILITATE FORM REMOVAL. RECTANGULAR CUTOUTS ARE ACCEPTABLE.
 5. THE CONTRACTOR IS RESPONSIBLE FOR THE PROPER FIT-UP OF THE PRECAST CONCRETE BARRIER RAIL ASSEMBLY AND PIN SUFFICIENT NUMBER OF PRECAST SECTIONS IN THE FABRICATIONS PLANT TO DETERMINE THAT PROPER FIT-UP CAN BE MAINTAINED ON ALL ROADWAY ALIGNMENT, CURVES AS WELL AS ON TANGENT. THIS IS TO BE DETERMINED EARLY IN FABRICATION.
 6. ATTACH REFLECTORS TO RAIL EVERY 30' [9.15 m]. USE ALUMINUM ALLOY MEETING THE ALUMINUM ASSOCIATION ALLOY AAS2-2-H32. FOLLOW THE MANUFACTURER'S SPECIFICATIONS FOR ADHESIVE MOUNTING. IN NARROW PAVED (FLUSH) MEDIAN APPLICATIONS, REFLECTORIZE BOTH SIDES.
 7. SEE DETAILED DRAWINGS 605-00 AND 605-10 FOR INFORMATION ON THE ADJACENT CONCRETE BARRIER RAIL SECTIONS. THE OPTIONAL TAPERED END DETAIL MAY ALSO BE USED HERE.
 8. GALVANIZE OR EPOXY COAT LOOPS AND CONNECTING PINS AFTER FABRICATION/BENDING. EPOXY COAT IN ACCORDANCE WITH SUBSECTION 711.02.1. GALVANIZE IN ACCORDANCE WITH ASTM A153, 8695 (CLASS 50) OR OTHER APPLICABLE ASTM GALVANIZING STANDARDS.
 9. 3/4" [19 mm] CHAMFER ENTIRE OPENING (OR SUFFICIENTLY ROUNDED SO THAT A SMOOTH EDGE RESULTS.) 1/2" [13 mm] CHAMFER IS ACCEPTABLE.

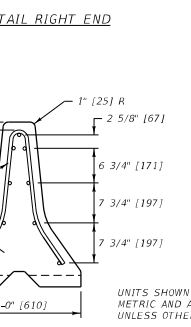
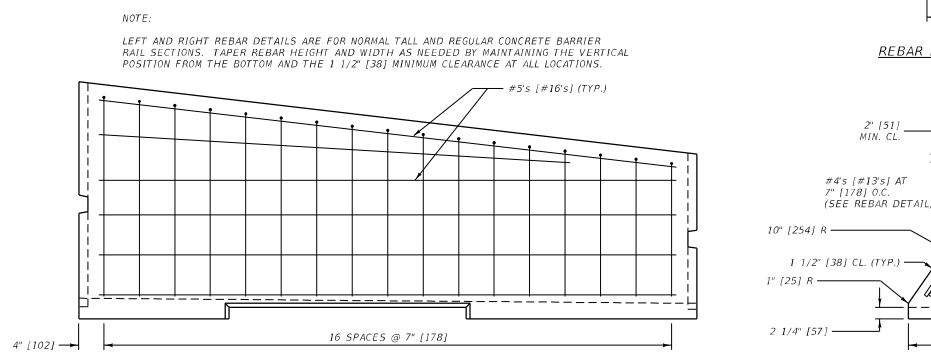
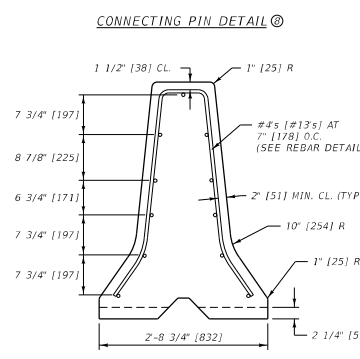

- REBAR DETAIL RIGHT END**
1. 2" [51] MIN. CL.
 2. 1" [25] R
 3. 2 5/8" [67]
 4. 6 3/4" [171]
 5. 7 3/4" [197]
 6. 7 3/4" [197]
 7. 1 1/2" [38] CL. (TYP.)
 8. 1" [25] R
 9. 2 1/4" [57]
 10. 2'-0" [610]

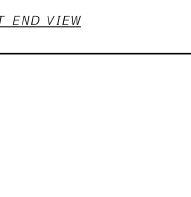
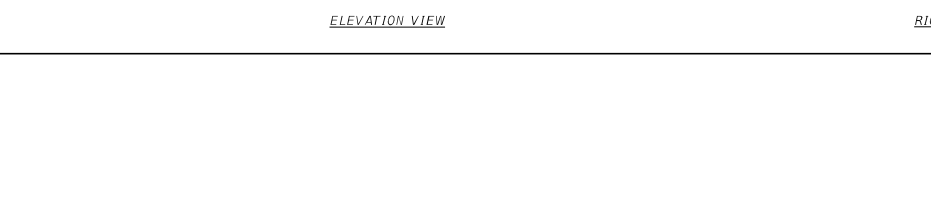
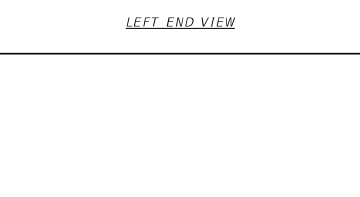

UNITS SHOWN IN BRACKETS [] ARE METRIC AND ARE IN MILLIMETERS (mm) UNLESS OTHER UNITS ARE SHOWN.

DETAILED DRAWING	
REFERENCE STANDARD SPEC. SECTION 554.556,605,711	DWG. NO. 605-15
CONCRETE BARRIER RAIL TRANSITION	
MDT MONTANA DEPARTMENT OF TRANSPORTATION	

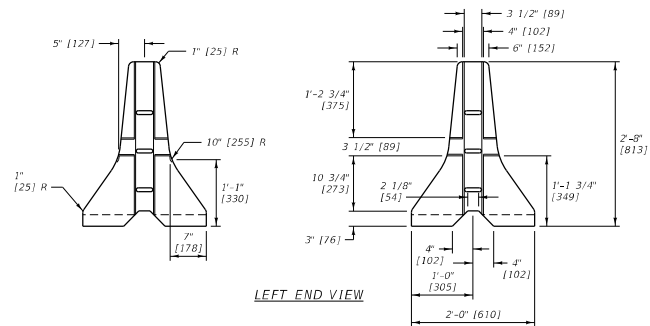

LEFT END VIEW

NOTE:

REBAR TYPICAL AT LEFT END ONLY. TAPER THE REBAR HEIGHT AS NEEDED BY MAINTAINING THE VERTICAL POSITION FROM THE BOTTOM AND THE 1 1/2" [38 mm] CLEARANCE AT ALL LOCATIONS.

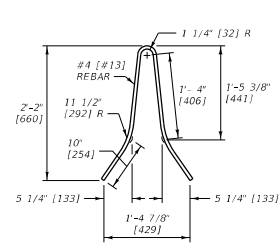

REBAR DETAIL LEFT END

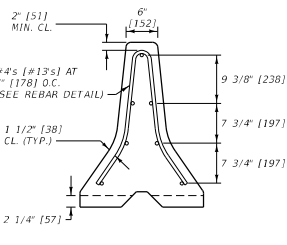

LEFT END VIEW

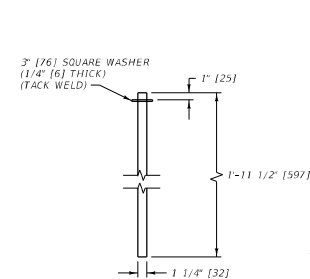

CONNECTING PIN DETAIL

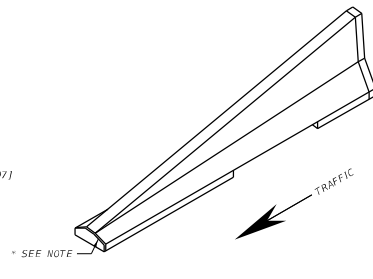

ISOMETRIC VIEW

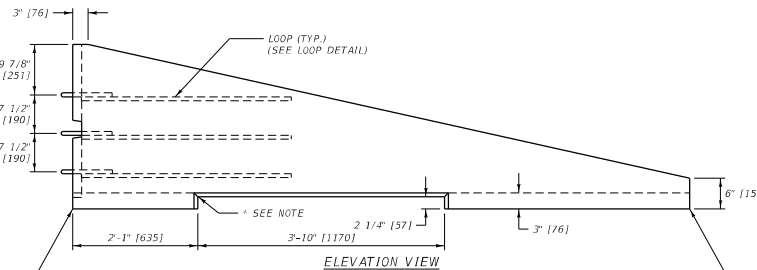

ELEVATION VIEW

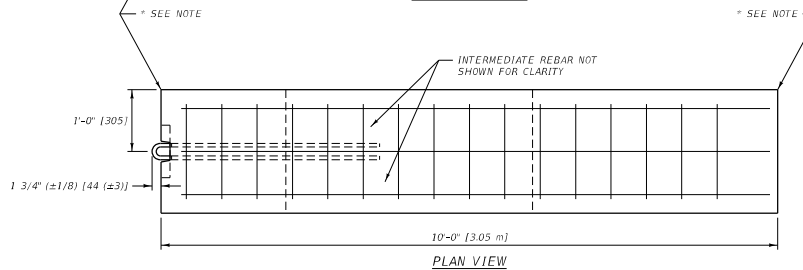

PLAN VIEW

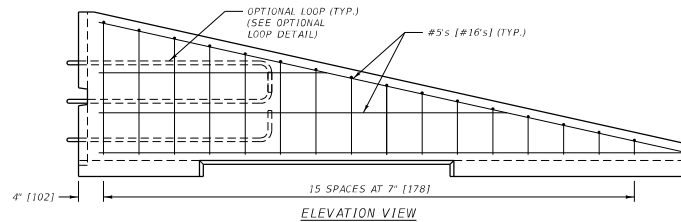

ELEVATION VIEW

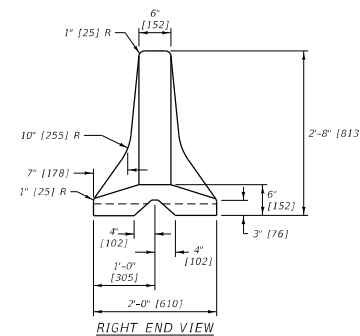

RIGHT END VIEW

NOTES:

- USE CLASS DECK CONCRETE OR EQUIVALENT.
- REINFORCING STEEL CONSISTS OF DEFORMED BARS CONFORMING TO AASHTO M 31 [31M], GRADE 60 [420].
- CONNECT EACH 10' [3.05 m] SECTION WITH CONNECTING PINS AS DETAILED AND CONFORMING TO AASHTO M 270 [270M], GRADE 36 [250] OR BETTER. CONNECTING PINS NEED NOT BE PAINTED.
- CUTOUTS ON LEFT END OF EACH SECTION ARE SHOWN WITH SLIGHT TAPER TO FACILITATE FORM REMOVAL. RECTANGULAR CUTOUTS ARE ACCEPTABLE.
- THE CONTRACTOR IS RESPONSIBLE FOR THE PROPER FIT-UP OF THE PRECAST CONCRETE BARRIER RAIL ASSEMBLY AND PIN SUFFICIENT NUMBER OF PRECAST SECTIONS IN THE FABRICATIONS PLAN TO DETERMINE THAT PROPER FIT-UP CAN BE MAINTAINED ON ALL ROADWAY ALIGNMENT CURVES AS WELL AS ON TANGENT. THIS IS TO BE DETERMINED EARLY IN FABRICATION.
- SEE DTL. DWG. NO. 605-00 FOR INFORMATION ON THE ADJACENT CONCRETE BARRIER RAIL SECTION. THE OPTIONAL TAPERED END DETAIL MAY ALSO BE USED HERE.
- GALVANIZE OR EPOXY COAT LOOPS AND CONNECTING PINS AFTER FABRICATION/ BENDING. EPOXY COAT IN ACCORDANCE WITH SUBSECTION 711.02.1. GALVANIZE IN ACCORDANCE WITH ASTM A153, B695 (CLASS 50) OR OTHER APPLICABLE ASTM GALVANIZING STANDARDS.

* 3/4" [19 mm] CHAMFER ENTIRE OPENING (OR SUFFICIENTLY ROUNDED SO THAT A SMOOTH EDGE RESULTS.) 1/2" [13 mm] CHAMFER IS ACCEPTABLE.

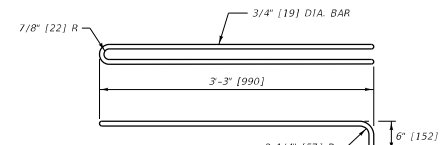

OPTIONAL LOOP DETAIL

LOOP FABRICATION REQUIREMENTS:

- USE REINFORCING STEEL CONFORMING TO ASTM A 706 [706M], GRADE 60 [420] FOR REBAR BEING WELDED TO LOOPS.
- LOOP ENDS CONSIST OF SMOOTH ROUND BARS CONFORMING TO AASHTO M 270 [270M], GRADE 36 [250].
- COLD BEND THE LOOPS BY USING A JIG THAT WILL PRODUCE AN ACCURATE RADIUS WITHOUT HARRING THE BAR. DO NOT HEAT THE BAR TO FACILITATE BENDING.
- WELD REBAR TO LOOPS MEETING SECTION 556 REQUIREMENTS USING 1/8" [3 mm] DIA. E8018 ROD. DO NOT TACK WELD THE PIECES TOGETHER PRIOR TO WELDING.
- NO ADDITIONAL WELDING IS PERMITTED ON THE SMOOTH ROUND BARS OR REINFORCING STEEL.

OPTIONAL LOOP FABRICATION REQUIREMENTS:

- USE CONTINUOUS SMOOTH ROUND BARS CONFORMING TO AASHTO M 270 [270M], GRADE 36 [250] TO FABRICATE THE OPTIONAL LOOPS.
- COLD BEND THE LOOPS BY USING A JIG THAT WILL PRODUCE AN ACCURATE RADIUS WITHOUT HARRING THE BAR. DO NOT HEAT THE BAR TO FACILITATE BENDING.
- NO WELDING IS PERMITTED ON THE SMOOTH ROUND BARS OR REINFORCING STEEL.

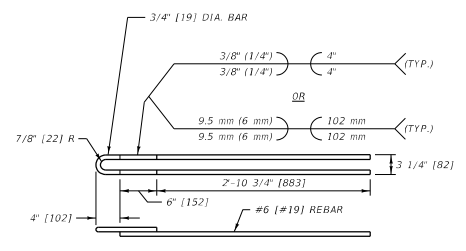

LOOP DETAIL

UNITS SHOWN IN BRACKETS [] ARE METRIC AND ARE IN MILLIMETERS (mm) UNLESS OTHER UNITS ARE SHOWN.

DETAILED DRAWING	
REFERENCE	DWG. NO.
STANDARD SPEC.	605-20
SECTION	354.605.711
CONCRETE BARRIER RAIL TERMINAL SECTION (ONE-WAY DEPARTURE)	
MDT MONTANA DEPARTMENT OF TRANSPORTATION	