

NOTES:

- Ⓐ THE MINIMUM DISTANCE FROM THE EDGE OF DRIVING LANE TO THE FIRST MAILBOX SHOULD BE THE CLEAR ZONE DISTANCE PLUS 6'-0" [1.8 m].
- Ⓑ THE WIDTH OF THE APPROACH AND MAILBOX TURNOUT COMBINED SHOULD NOT EXCEED 40'-0" [12.0 m]. IF MORE THAN 40'-0" [12.0 m], THE MAILBOX TURNOUT WIDENING IS NOT REQUIRED.

NOTES:

- ① LOCATE NEW INSTALLATIONS, IF POSSIBLE, ON THE RIGHT SIDE OF THE PUBLIC ROAD OR PRIVATE APPROACH.
- ② APPROACH QUANTITIES ARE NOT INCLUDED IN MAILBOX TURNOUT QUANTITIES.
- ③ PROVIDE ADEQUATE APPROACH RADIUS FOR THIS TURNOUT. ADJUST THE RADIUS BASED ON FIELD CONDITIONS AND DOCUMENT REASONS DURING THE FIELD REVIEW.
- ④ SEE DETAILED DRAWING NUMBER 203-05 FOR ADDITIONAL GUIDANCE.

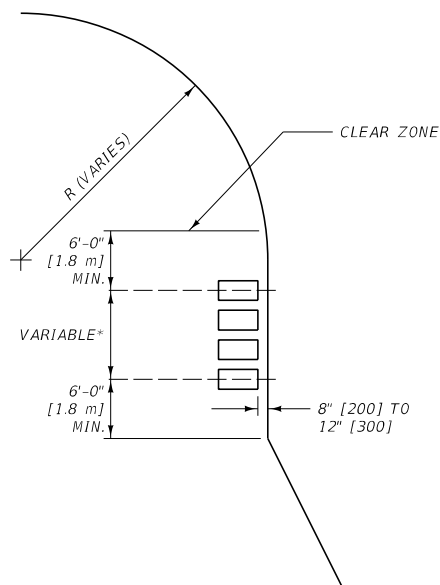

NOTE:

* THE MINIMUM SPACING BETWEEN MAILBOXES IS EQUAL TO THREE-FOURTHS OF THEIR HEIGHT ABOVE THE GROUND. SEE DTL. DWG. NO. 623-20 AND 623-25 FOR MAILBOX DETAILS.

MAILBOX LOCATION DETAIL

UNITS SHOWN IN BRACKETS [] ARE METRIC AND ARE IN MILLIMETERS (mm) UNLESS OTHER UNITS ARE SHOWN.

DETAILED DRAWING	
REFERENCE	DWG. NO.
STANDARD SPEC.	623-10
SECTION 623	

APPROACH
MAILBOX TURNOUT

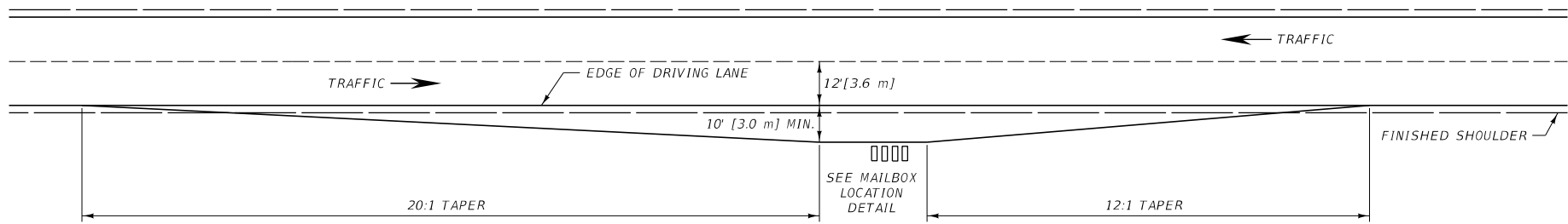

TURNOUT WITHOUT APPROACH

NOTE:
ACTUAL SIZE AND LOCATION TO BE DETERMINED BY
THE PROJECT MANAGER.

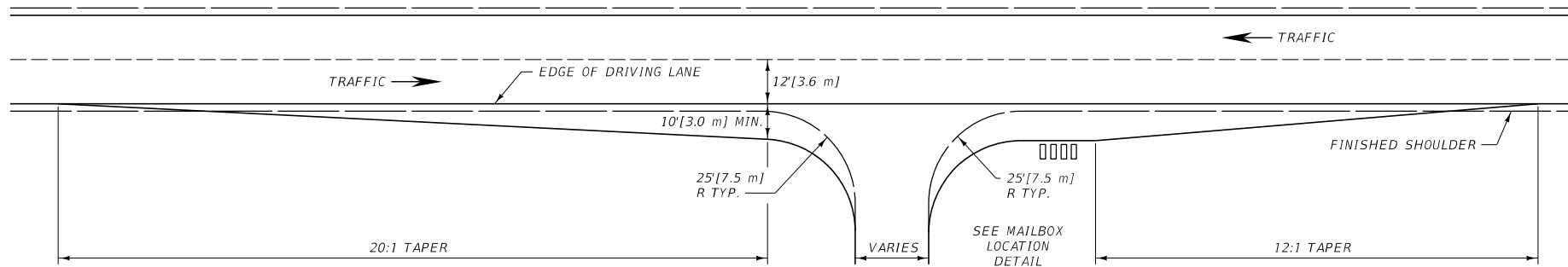

TURNOUT WITH APPROACH

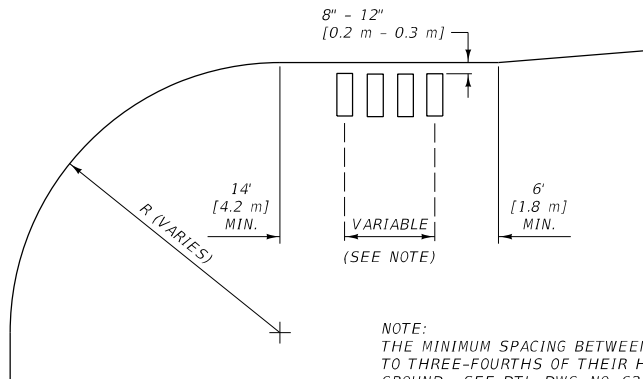

NOTE:
THE MINIMUM SPACING BETWEEN MAILBOXES IS EQUAL
TO THREE-FOURTHS OF THEIR HEIGHT ABOVE THE
GROUND. SEE DTL. DWG. NO. 623-20 AND 623-25
FOR MAILBOX DETAILS.

MAILBOX LOCATION DETAIL

NOTES:

- ① LOCATE NEW INSTALLATIONS, IF POSSIBLE, ON THE FAR RIGHT SIDE OF AN INTERSECTION WITH A PUBLIC ROAD OR PRIVATE DRIVEWAY.
- ② APPROACH QUANTITIES ARE NOT INCLUDED IN TURNOUT QUANTITIES.

UNITS SHOWN IN BRACKETS [] ARE
METRIC AND ARE IN MILLIMETERS (mm)
UNLESS OTHER UNITS ARE SHOWN.

DETAILED DRAWING	
REFERENCE STANDARD SPEC. SECTION 623	DWG. NO. 623-15
MAILBOX TURNOUT	
MDT MONTANA DEPARTMENT OF TRANSPORTATION	

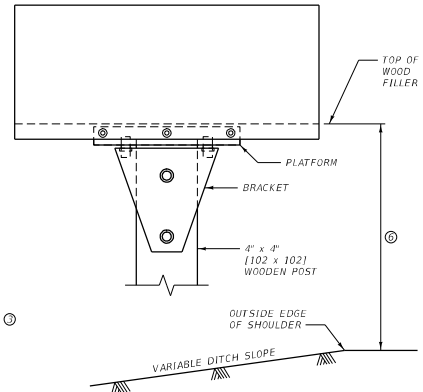
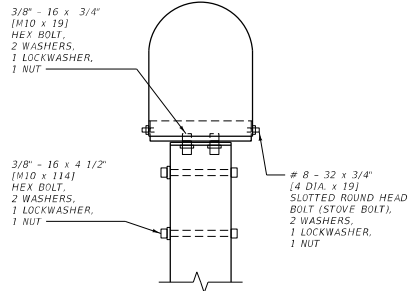

SINGLE MAILBOX ASSEMBLY ①

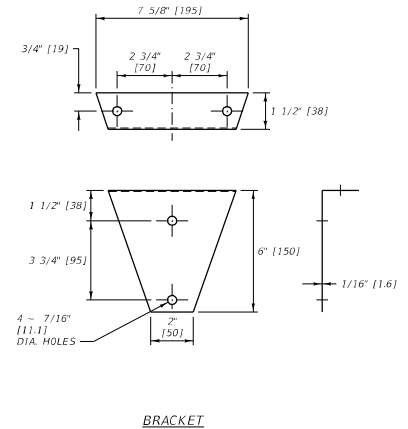
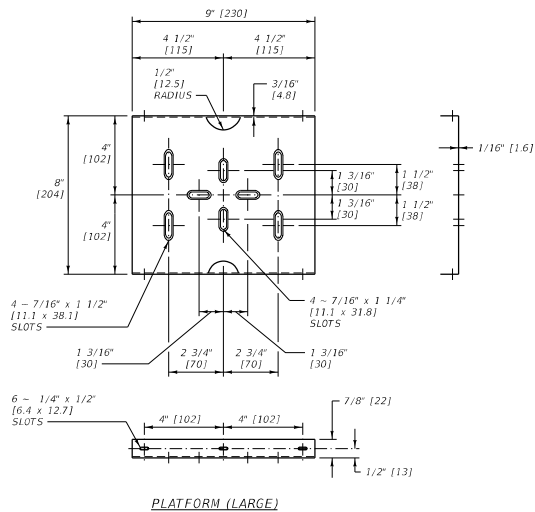
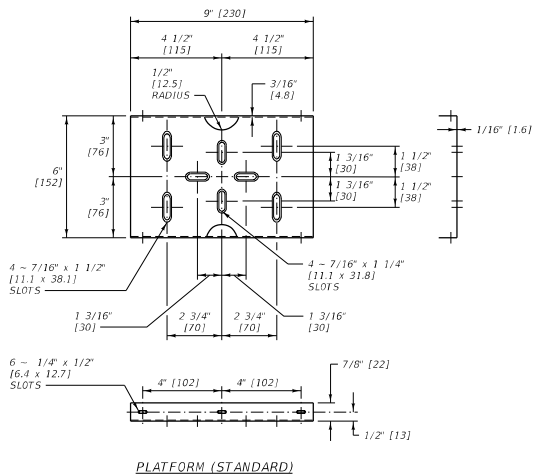

- NOTES:
- ① GALVANIZE ALL MATERIALS MEETING SECTION 711.
 - ② STAKE MAILBOX LOCATIONS BEFORE INSTALLATION FOR PROPER HEIGHT AND DISTANCE FROM THE ROADWAY. ONCE STAKED, NOTIFY THE PROJECT MANAGER AND THE POST OFFICE. THE PROJECT MANAGER AND POSTMASTER/MAILCARRIER ARE ALLOWED 48 HOURS TO REVIEW AND MODIFY THE STAKED LOCATIONS PRIOR TO FINAL INSTALLATION.
 - ③ OTHER NCHRP 350 OR MASH CRASH TESTED MAILBOX SUPPORTS AND ASSEMBLIES MAY ALSO BE USED.
 - ④ LOCATE THE MAILBOX 8" [0.2 m] TO 12" [0.3 m] OUTSIDE THE EDGE OF THE SHOULDER OR 6" [0.15 m] TO 12" [0.3 m] FROM THE FACE OF CURB.
 - ⑤ FOR MULTIPLE MAILBOX INSTALLATIONS, SPACE THE MAILBOX SUPPORTS A MINIMUM DISTANCE OF 42" [1.05 m] APART.
 - ⑥ FOR RURAL LOCATIONS USE A 38" TO 42" [965 TO 1065] MOUNTING HEIGHT. FOR URBAN LOCATIONS USE A 45" TO 48" [1145 TO 1220] MOUNTING HEIGHT.
 - ⑦ SEE "A GUIDE TO MAILBOX SAFETY IN MONTANA" FOR ADDITIONAL INFORMATION.

UNITS SHOWN IN BRACKETS [] ARE METRIC AND ARE IN MILLIMETERS (mm) UNLESS OTHER UNITS ARE SHOWN.

DETAILED DRAWING	
REFERENCE STANDARD SPEC. SECTION 623 & 711	DWG. NO. 623-20
MAILBOX DETAIL	
MDT MONTANA DEPARTMENT OF TRANSPORTATION	

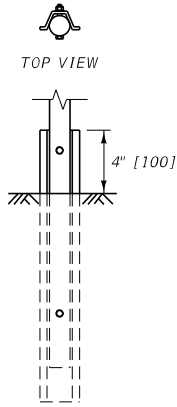

PIPE/POST CONNECTION
ROADWAY VIEW

38" TO 42" [965 TO 1065] RURAL
45" TO 48" [1145 TO 1220] URBAN

DRILL 5/16" [7.9] DIA. HOLES FOR 1/4" [M6] DIA. CARRIAGE BOLTS

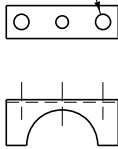

TAIL PIPE CLAMP

NO. 10 x 1" [5 DIA. (#10) x 25] SHEET METAL SCREWS (9 REQUIRED)

1 1/2" [38.1] TAIL PIPE CLAMP (AVAILABLE WHERE AUTOMOBILE TAIL PIPE FITTINGS ARE SOLD)

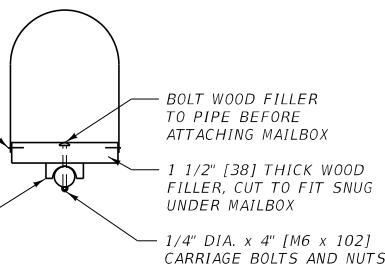

SECTION A-A

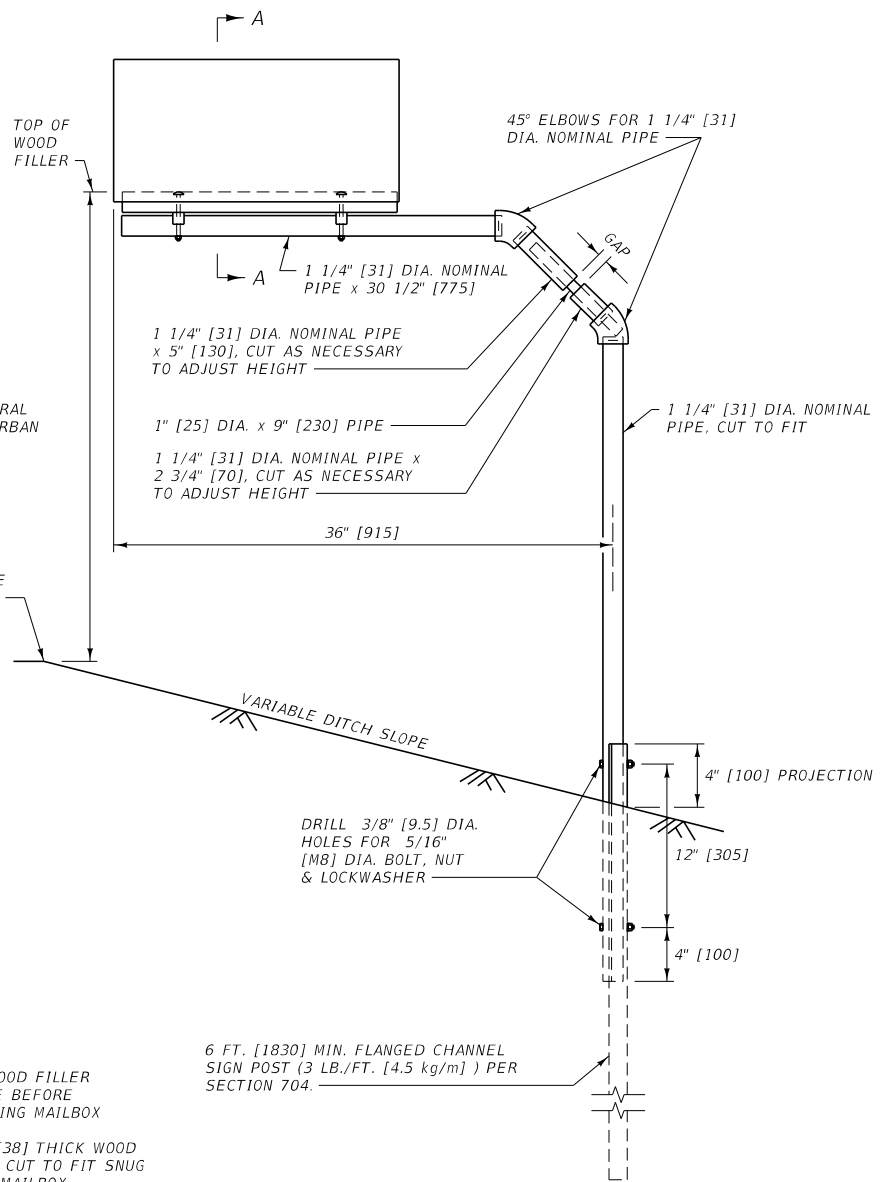

MAILBOX SUPPORT

STEEL PIPE WITH FITTINGS AND STEEL FENCE POST

NOTES:

- ① GALVANIZE ALL MATERIALS MEETING SECTION 711.
- ② STAKE MAILBOX LOCATIONS BEFORE INSTALLATION FOR PROPER HEIGHT AND DISTANCE FROM THE ROADWAY. ONCE STAKED, NOTIFY THE PROJECT MANAGER AND THE POST OFFICE. THE PROJECT MANAGER AND POSTMASTER/MAIL CARRIER ARE ALLOWED 48 HOURS TO REVIEW AND MODIFY THE STAKED LOCATIONS PRIOR TO FINAL INSTALLATION.
- ③ OTHER NCHRP 350 OR MASH CRASH TESTED MAILBOX SUPPORTS AND ASSEMBLIES MAY ALSO BE USED.
- ④ LOCATE THE MAILBOX 8" TO 12" [0.2 TO 0.3 METERS] OUTSIDE THE EDGE OF THE SHOULDER OR 6" TO 12" [0.15 TO 0.3 METERS] FROM THE FACE OF CURB.
- ⑤ SEE "A GUIDE TO MAILBOX SAFETY IN MONTANA", FOR ADDITIONAL INFORMATION.

UNITS SHOWN IN BRACKETS [] ARE METRIC AND ARE IN MILLIMETERS (mm) UNLESS OTHER UNITS ARE SHOWN.

DETAILED DRAWING	
REFERENCE	DWG. NO.
STANDARD SPEC.	623-25
SECTION	623,704, AND 711

OPTIONAL MAILBOX
DETAIL

ELEVATION VIEW

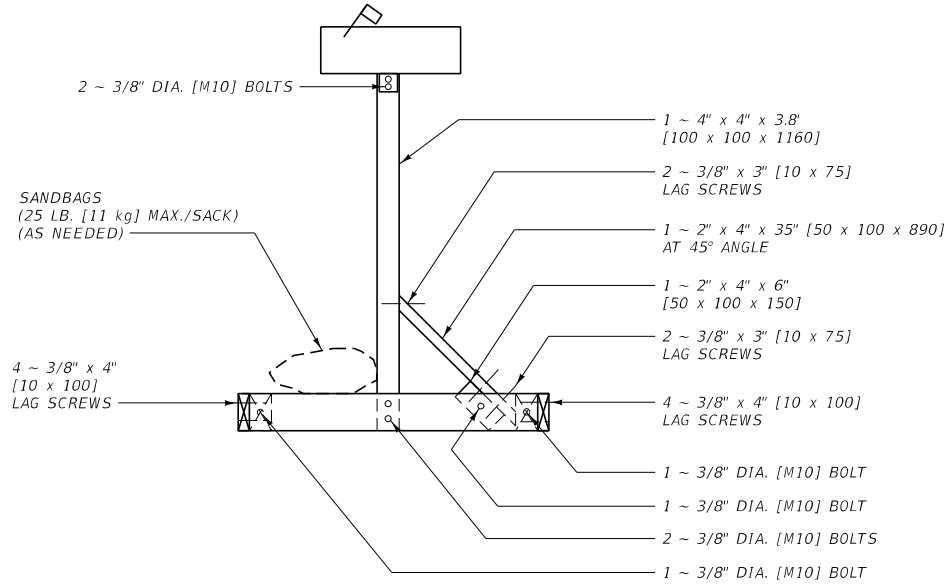

FRONT VIEW

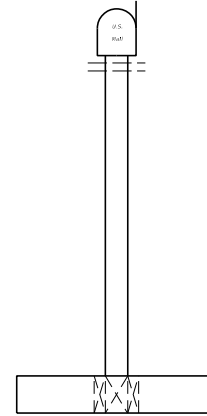

NOTES:

- ① THIS MOUNTING DEVICE IS INTENDED FOR USE IN CONSTRUCTION ZONES.
- ② BOLT PLACEMENT IS SYMMETRICAL THROUGHOUT MOUNTING BRACKET.
- ③ ALL BOLT CONNECTIONS ARE FINISHED WITH A WASHER AND NUT.
- ④ FOR THE POST USE EITHER DOUGLAS FIR OR HEM FIR, WHICH IS SURFACED FOUR SIDES (S4S) AND FREE OF HEART CENTER (FOHC).

PLAN VIEW

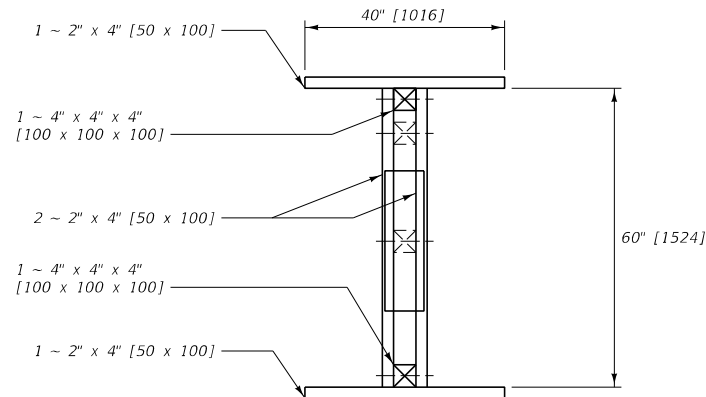

UNITS SHOWN IN BRACKETS [] ARE METRIC AND ARE IN MILLIMETERS (mm) UNLESS OTHER UNITS ARE SHOWN.

DETAILED DRAWING	
REFERENCE STANDARD SPEC. SECTION 623	DWG. NO. 623-30
TEMPORARY MAILBOX SUPPORT	
 MDT MONTANA DEPARTMENT OF TRANSPORTATION	

MOUNTING SYSTEM

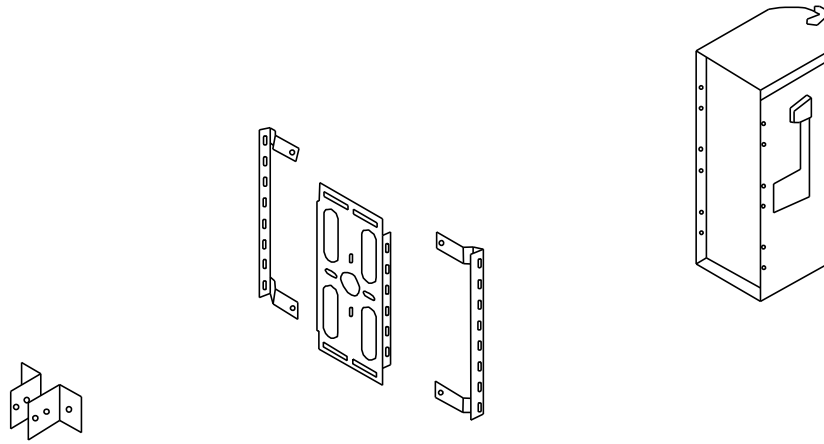

NOTES:

- ① THIS MOUNTING DEVICE IS INTENDED FOR USE IN CONSTRUCTION ZONES.
- ② BOLT PLACEMENT IS SYMMETRICAL THROUGHOUT MOUNTING BRACKET.
- ③ ALL BOLT CONNECTIONS ARE FINISHED WITH A WASHER AND NUT.

ATTACHMENT DETAILS

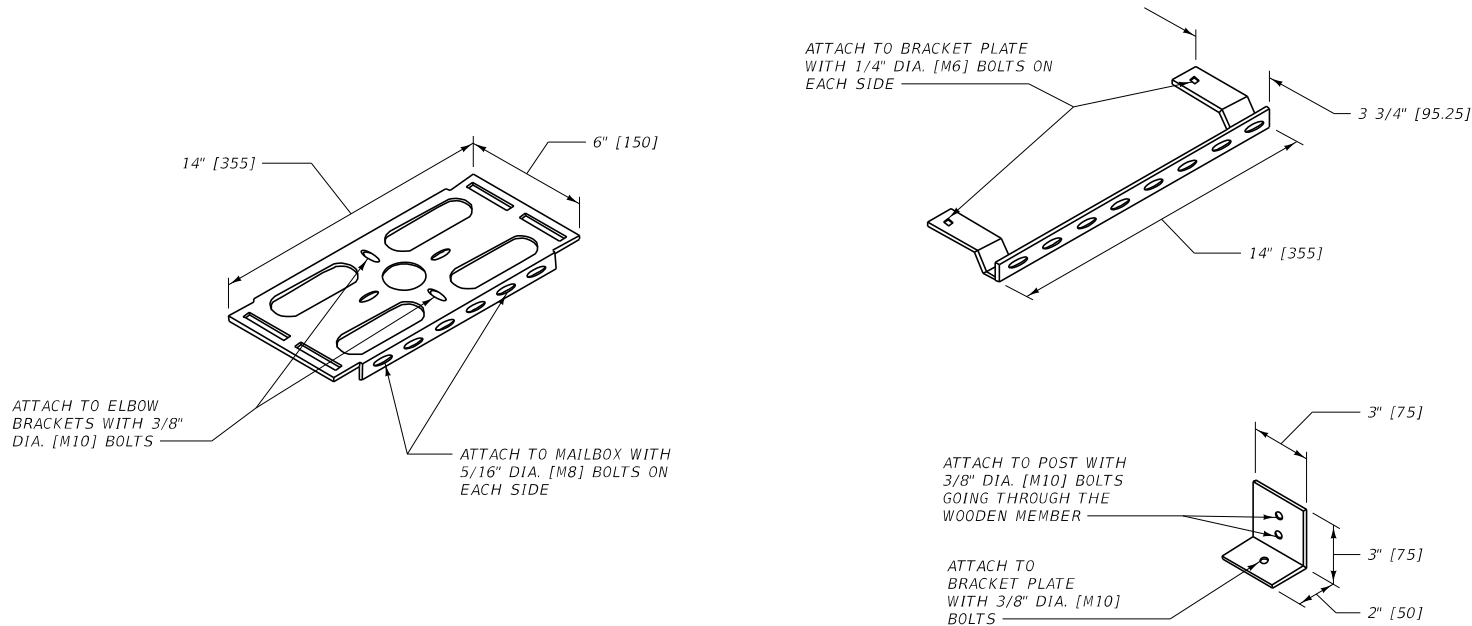

UNITS SHOWN IN BRACKETS [] ARE METRIC AND ARE IN MILLIMETERS (mm) UNLESS OTHER UNITS ARE SHOWN.

DETAILED DRAWING	
REFERENCE	DWG. NO.
STANDARD SPEC.	623-35
SECTION 623	
TEMPORARY MAILBOX SUPPORT BRACKET DETAILS	
MDT MONTANA DEPARTMENT OF TRANSPORTATION	