



Biological Assessment

South Avenue Bridge Project

Bitterroot River - W of Missoula

BR 9032(65)

UPN 6296000

Missoula County, Montana

September 13, 2018

Prepared for:



Missoula County Department of Public Works
6086 Training Drive
Missoula, MT 59808

Prepared by:



HDR
700 SW Higgins Avenue, Ste. 200
Missoula, MT 59803

EXECUTIVE SUMMARY

Missoula County, in cooperation with the Montana Department of Transportation and Federal Highway Administration, is proposing to construct a new bridge across the Bitterroot River at the western terminus of South Avenue to connect with River Pines Road immediately west of the river. The proposed South Avenue Bridge would involve construction of a new 2-lane bridge (one travel lane in each direction) that provides for bicycle/pedestrian accommodations separated from vehicular traffic. The bridge design currently being evaluated is a four span welded plate girder design approximately 746 feet long. The project limits extend between the intersection of South Avenue and Hanson Drive to the east and River Pines Road to the west. A segment of River Pines Road will be realigned to include T-intersection on the west side of the river. The project includes removal of the existing single-lane Maclay Bridge on North Avenue located approximately 0.4 mile downstream of the proposed bridge location.

The project is located within Missoula County, outside of the city limits of Missoula. The project is located in Sections 26, 27, 34, and 35 of Township 13 North, Range 20 West, Montana Principle Meridian, and is centered at approximately 46.8491° North latitude and 114.1043° West longitude.

This Biological Assessment (BA) addresses the proposed action in compliance with Section 7(c) of the Endangered Species Act (ESA) of 1973, as amended. The July 16, 2018 publication of *Endangered, Threatened, Proposed and Candidate Species Montana Counties* (USFWS 2018a) available through the U.S. Fish and Wildlife Service's (USFWS) Montana Ecological Field Office was reviewed in conjunction with correspondence with the USFWS to identify the species to be considered with respect to the proposed project. Table ES-1 presents the listed, proposed, and candidate species considered with respect to this project, including a summary of findings for each of the listed species.

Table ES-1. Summary of Findings for Species Designated as Federally Threatened, Endangered, Proposed, or Candidate

Common Name	Scientific Name	Status ^a	Finding
Whitebark Pine	<i>Pinus albicaulis</i>	C	Not Likely to Jeopardize the Continued Existence
Canada Lynx	<i>Lynx canadensis</i>	LT, CH	No Effect
Bull Trout	<i>Salvelinus confluentus</i>	LT, CH	May Affect, Likely to Adversely Affect
Yellow-billed cuckoo (western pop.)	<i>Coccyzus americanus</i>	LT	May Affect, Not Likely to Adversely Affect
Water Howellia	<i>Howellia aquatilis</i>	LT	No Effect
Grizzly Bear	<i>Ursus arctos horribilis</i>	LT	No Effect
Wolverine	<i>Gulo gulo</i>	P	Not Likely to Jeopardize the Continued Existence
Red Knot	<i>Calidris canutus rufa</i>	LT	No Effect

Sources: USFWS 2018a

^a C = Candidate; CH = Designated Critical Habitat; LT = Listed Threatened; P = Proposed

Contents

1	Project Overview	1
1.1	Federal Nexus	1
1.2	Project Background	1
1.3	Project Location and Description	2
1.3.1	South Avenue Bridge Construction	4
1.3.2	Maclay Bridge Removal	5
1.4	Project Area and Setting	5
1.4.1	Ecological Setting	5
1.4.2	Land Use and Land Ownership	6
1.4.3	Environmental Baseline	6
2	Methodology and Action Area	6
2.1	Methods	6
2.1.1	Field Survey	7
2.2	Project Action Area	7
2.2.1	Aquatic Portion of the Action Area	8
2.2.2	Terrestrial Portion of the Action Area	9
3	Threatened and Endangered Species Biological Assessment	11
3.1	Previous Effect Determinations in the Preliminary Biological Assessment	11
3.2	Bull Trout	12
3.2.1	Status and Life History	12
3.2.2	Occurrence in Action Area	13
3.2.3	Bull Trout Critical Habitat	13
3.2.4	Potential Impacts on Bull Trout and Bull Trout Critical Habitat	16
3.2.5	Conservation Measures for Bull Trout	21
3.2.6	Determination of Effects	23
3.3	Western Yellow-Billed Cuckoo	23
3.3.1	Status and Life History	23
3.3.2	Occurrence in Action Area	24
3.3.3	Potential Impacts on the Yellow-Billed Cuckoo	26
3.3.4	Conservation Measures for Yellow-billed Cuckoo	27
3.3.5	Determination of Effects	27
3.4	Potential Cumulative Effects Analysis	28
4	References	30

Tables

Table 2-1.	YBCU Survey Schedule	7
Table 3-1.	Federally Listed Species Occurring in Missoula County, MT	11

Figures

Figure 1-1.	Proposed Project and Project Area	3
Figure 2-1.	Project Action Area	10

Appendices

APPENDIX A: Yellow-billed Cuckoo Survey Report

APPENDIX B: Representative Site Photos

APPENDIX C: Preliminary Bridge Layout Plan
Preliminary Maclay Bridge Removal Plan

This page is intentionally left blank.

1 Project Overview

1.1 Federal Nexus

This Biological Assessment (BA), prepared for Missoula County and the Montana Department of Transportation (MDT), addresses the proposed construction of a new bridge across the Bitterroot River at the western terminus of South Avenue and the removal of the existing Maclay Bridge located in Missoula County. This BA was prepared in compliance with Section 7(c) of the Endangered Species Act (ESA) of 1973, as amended. Section 7 of the ESA directs federal agencies to ensure that actions they authorize, fund, and/or conduct are not likely to jeopardize the continued existence of any federally proposed or listed species, or result in destruction or adverse modification of critical habitat for such species. Section 7(c) of the ESA requires that federal agencies contact the U.S. Fish and Wildlife Service (USFWS) and the National Marine Fisheries Service (NMFS; jointly referred to as the “Services”) before beginning any construction activity to determine if federally listed threatened and endangered (T&E) species or designated critical habitat may be present in the vicinity of a proposed project. A BA must be prepared if actions by a federal agency, or permits issued by a federal agency, may result in effects to T&E species that occur in the vicinity of a proposed project. The proposed project will require a Section 404 Permit issued by the U.S. Army Corps of Engineers (USACE) to authorize work occurring within a jurisdictional water body. With respect to the proposed action, the USACE, Omaha District, is the federal agency permitting the project.

This BA evaluates the potential effects of the proposed project on ESA-listed species and their associated critical habitat. Specific project design elements are identified that avoid or minimize adverse effects of the proposed project on listed species and critical habitat.

1.2 Project Background

Replacing Maclay Bridge has long been a priority of Missoula County dating back as far as 1994, when an Environmental Assessment (EA) for the *Maclay Bridge Site Selection Study* was developed (Carter & Burgess 1994). The Preferred Alternative identified in the environmental document was a new bridge located at the end of South Avenue. A Finding of No Significant Impact (FONSI) on the 1994 EA was never issued by FHWA, and, at the request of Missoula County, the project identified within the EA was not advanced. Special project demonstration funds were initially intended to be used to fund the project; however, Missoula County was not able to obtain the funding. In 2002, Missoula County nominated the bridge replacement project to receive funding from MDT’s Off-System Bridge Program.

Instead of immediately entering into the project development phase and environmental documentation, Missoula County decided to delay the project and, with assistance from MDT, conduct a pre-National Environmental Policy Act (NEPA)/Montana Environmental Policy Act (MEPA) planning study. The purpose of the planning study was to document existing and projected conditions, take a fresh look at and evaluate a range of

alternatives, and conduct additional outreach with the public and resource agencies. In 2013, the *Maclay Bridge Planning Study* (Robert Peccia & Associates 2013) identified the South 1 Alignment (3E.1) as the preferred alignment. The South 1 Alignment (3E.1), similar to the 1994 EA Preferred Alternative, includes extending the westernmost limits of South Avenue with a new bridge crossing the Bitterroot River and connecting to River Pines Road on the west side of the river. This alignment was determined best able to increase safety and efficiency for the traveling public based on multiple criteria relating to safety, geometric and environmental concerns.

On April 17, 2013, the Missoula County Commissioners unanimously voted in favor of accepting the 2013 planning study recommendation and moving forward with the plan to replace the existing Maclay Bridge with a new bridge on South Avenue.

A Biological Resource Report (BRR) and Preliminary Biological Assessment (PBA) was completed in January 2017 and the report can be downloaded at the project website at <http://www.southavenuebridge.com/documents>. Following publication of the BRR/PBA it was recommended by the USFWS to conduct a presence/absence survey for the yellow-billed cuckoo. Surveys were conducted in June and July of 2018 and the results are summarized in Section 3.3. The technical survey report discussing the results of the yellow-billed cuckoo presence/absence survey is included as Appendix A.

1.3 Project Location and Description

Missoula County, in cooperation with the MDT and Federal Highway Administration (FHWA), is proposing to construct a new bridge across the Bitterroot River at the western terminus of South Avenue to connect with River Pines Road immediately west of the river. The proposed South Avenue Bridge will involve construction of a new 2-lane bridge (one travel lane in each direction) that provides for bicycle/pedestrian accommodations separated from vehicular traffic. The project limits extend between the intersection of South Avenue and Hanson Drive to the east and the intersection of River Pines Road and Blue Heron Lane to the west. The proposed project includes new right-of-way (ROW) acquisition. The project includes removal of the existing single-lane Maclay Bridge on North Avenue located approximately 0.4 mile downstream of the proposed bridge. The proposed project and associated study area are shown in Figure 1-1.

The project is located within Missoula County, outside of the city limits of Missoula. The project is located in Sections 26, 27, 34 and 35 of Township 13 North, Range 20 West, Montana Principle Meridian, and is centered at approximately 46.8491° North latitude and 114.1043° West longitude.



Figure 1-1. Proposed Project and Project Area

Construction of the project is anticipated to occur over two seasons, with construction of the new bridge occurring in year one and removal of the Maclay Bridge in the second year. Work within the river would be scheduled to occur during the summer in-water work window (July 1 through September 30) (USFWS 2015a). The methods for constructing the new bridge and removing Maclay Bridge are currently unknown and would depend largely on contractor approach. It is likely that the extent of in-water work could include temporary work structures such as cofferdams, diversion blocks, work trestles, or other means to access and work within, or over, the Bitterroot River. To the extent possible, construction staging for the project will occur within existing ROW and limited to previously disturbed areas. Additional details specific to each major work element are further described below.

1.3.1 South Avenue Bridge Construction

The bridge design currently being evaluated is a four span welded plate girder design approximately 746 feet long. The proposed bridge is being designed to span the approximately 730-foot-wide regulatory floodway and minimize the structure footprint within the floodplain. The proposed bridge structure would include three piers: two located within the active river channel and one located approximately 160 feet landward east of the river channel above the ordinary high water mark (OHWM). The bridge abutments and associated rip rap would be constructed at an elevation above the OHWM. The pier type and size are not finalized and the foundations will be determined following final geotechnical recommendations. However, two pier options are currently being evaluated, which include:

- Drilled shaft foundation: Each pier would include two drilled shafts 7-feet in diameter spaced 30 feet apart on centers and aligned with the direction of flow of the river. Piers would be constructed first by installing the steel casings using a vibratory hammer to isolate the work area. The foundations would then be drilled out within the casings and filled with concrete.
- Driven pile foundation: Each pier would include a 3-foot by 25-foot wall on top of a pile-supported foundation aligned with to the flow of the river. Piers would be constructed first by installing cofferdams to isolate the work area, piles would be driven likely using a combination of impact and vibratory hammers, and the foundations would be formed of concrete.

On the west side of the Bitterroot River, the bridge alignment and approaches have been shifted north of the existing River Pines Road to increase separation between O'Brien Creek and new construction. River Pines Road will be realigned to include a T-intersection on the west side of the river to provide access to residences along River Pines Road and Riverside Drive. The existing Big Flat Ditch irrigation culvert will be extended to the north to accommodate the alignment shift. These roadway realignments will result in the abandonment and obliteration of two segments of River Pines Road. Following construction, these areas would be restored with native riparian species, which would create an increased vegetative buffer between the road and the Bitterroot River and O'Brien Creek. Riparian vegetation clearing would be necessary within the project construction footprint of the new bridge as well as a small area of vegetated gravel bar surrounding the piers to be removed at Maclay Bridge (see following section).

Stormwater would be managed by conveying it off the bridge (i.e., away from the active river channel) and dispensed onto adjacent upland areas at either bridge end. There may be a need for a stormwater detention area on the west side of the bridge; however, further analysis is necessary to determine the stormwater requirements.

1.3.2 Maclay Bridge Removal

Once the new South Avenue Bridge is constructed and operational the existing Maclay Bridge will be fully removed, including the piers, piles, and abutments. The structure would be dismantled and/or demolished from the top down beginning with removal of the main span, pony truss, and concrete single tee spans. Equipment will be required to access the piers but will avoid working in the main river channel. To minimize the impact on the river, the piers and piles would likely be isolated using cofferdams or diversion blocks and excavated to a minimum depth of 3 feet below the thalweg. Both bridge abutments would be removed. The west abutment currently protrudes into the river channel and, once the abutment is removed, the fill associated with the old abutment would be graded back to increase hydraulic capacity and alleviate potential downstream erosion. Existing rip rap would be set back in place and tied in with the existing slopes to ensure that the protection measures of the abutment area are not compromised and do not increase the risk to existing infrastructure upstream and downstream of the site. The restored abutment areas would be revegetated with willow cuttings to improve slope stability and riparian habitat.

1.4 Project Area and Setting

1.4.1 Ecological Setting

The study area is located within Bitterroot River floodplain within the Middle Rockies level 3 ecoregion and the Bitterroot-Frenchtown Valley level 4 ecoregion (Woods et al. 2002, USEPA 2012). The following description is summarized from Woods et al. (2002) and USDA NRCS (2016a). The Bitterroot-Frenchtown Valley is an intermontane valley with floodplains, terraces, hills, and fans, with thick alluvial, colluvial, outwash and till soils formed out of end moraines of alpine glaciers. Climate in the Bitterroot-Frenchtown Valley is characterized by precipitation that averages 12 to 24 inches per year, which mainly occurs in fall, winter and spring, and with much of the precipitation in the winter falling as snow. Wintertime temperatures typically fall below freezing, and summertime temperatures peak in the high 80's. Snowmelt from surrounding mountains contributes to high stream flows in the spring. In the vicinity of the project, the Bitterroot River floodplain has seen moderate development. Residential and agricultural land uses about the Bitterroot River and existing blocks of hardwood and coniferous riparian forest within the project vicinity are relatively small and non-contiguous.

The study area intersects with the boundaries of multiple Hydrologic Units. The study area is situated within the fifth-level Bitterroot River-Miller Creek watershed (south portion of study area) Hydrologic Unit Code (HUC) 1701020516 and the Clark Fork River-Rattlesnake Creek watershed (north portion of study area) HUC 1701020401. More specifically, three sixth-level subwatersheds converge at the location of the study area and include: Bitterroot River-Hayes Creek (HUC 170102051603); Clark Fork River-

Marshall Creek (HUC 170102040104); and O'Brien Creek (HUC 170102051602) (USGS 2014).

1.4.2 Land Use and Land Ownership

The study area is situated at the western edge and outside of Missoula's city limits and is considered a part of Missoula's Target Range neighborhood. The predominant land use within the project vicinity is residential with developed parcels ranging in size from one-half acre and larger. Low- to medium-density residential development exists on both the east and west sides of the river. A small, approximately 4-unit mobile home park is located at the western terminus of South Avenue. The project vicinity includes open space primarily within the Bitterroot River floodplain. This includes an approximately 8.5-acre undeveloped island located between the proposed bridge location and the existing Maclay Bridge, which contains a 1.0-acre conservation park identified as Dinsmore River Four Park owned by Missoula County (Missoula County 2016). Agricultural uses consisting of mostly hay production also exist within the study area on the west side of the river (MSL 2016).

Land ownership within the immediate vicinity of the study area is predominantly privately owned. Missoula County owns the ROW that includes South Avenue, which tapers in width west of the cul-de-sac and beyond the paved roadway. Per Montana Code Annotated (MCA 70-16-201) the State of Montana owns the riverbed of the Bitterroot River (and all other navigable rivers) from low water mark to low water mark.

1.4.3 Environmental Baseline

Regulations implementing the ESA (50 CFR 402.02) define the environmental baseline as the past and present impacts of all Federal, State or private actions and other human activities in the action area. Representative project site photographs are presented in Appendix B. Environmental baseline conditions for terrestrial and aquatic areas within the project area are described in the BRR/PBA as published in January 2017, which describes general habitat and vegetation, project area waterways and wetlands.

2 Methodology and Action Area

2.1 Methods

Information reported within this section was obtained from a combination of agency consultation and coordination, a review of literature and database searches, and on-site field investigation. The July 16, 2018 publication of *Endangered, Threatened, Proposed and Candidate Species by Montana County* for Missoula County available through the USFWS's Montana Ecological Field Office (USFWS 2018a) was reviewed to determine the federally listed species potentially occurring in Missoula County. A list of federally listed endangered, threatened, proposed, and candidate species to be considered for this project was generated based on the USFWS and MTNHP data in conjunction with correspondence with the USFWS. The MTNHP is a clearing house for federally listed threatened, endangered, proposed and candidate species in the state of Montana. Geospatial data containing federally listed species distribution and occurrence data in the

vicinity of the study area was obtained from MTNHP on August 1, 2016. For analysis purposes, a one-mile radius search area was used to determine if any federally listed terrestrial species have been documented in the vicinity of the proposed project. Existing documentation reviewed for this section includes the following:

- Montana Natural Heritage Program (MTNHP 2016a) Database
- Montana Fish, Wildlife and Parks Montana Fisheries Information System (MFISH) (FWP 2016)

Fish and wildlife biologists from MDT, FWP and USFWS were consulted regarding fish and wildlife resources in the study area.

2.1.1 Field Survey

HDR staff conducted reconnaissance-level field surveys at the project site on October 6 and 8, 2015. HDR staff qualitatively documented instream habitat of the Bitterroot River approximately 200 feet upstream and downstream of the proposed bridge alignment and approximately 100 feet upstream and downstream of Maclay Bridge. General observations of stream morphology, substrate, instream habitat features such as large woody debris, and general streambank and riparian conditions were noted during the field investigation.

Additionally, HDR conducted protocol presence/absence surveys for the YBCU during the period of June 17 through July 30 of 2018. Four separate surveys (see Table 2.1) for the YBCU were conducted following the USFWS official survey protocol (Haltermann et al. 2015). Additionally, all incidental observations of wildlife species or sign were recorded during all field surveys.

Table 2-1. YBCU Survey Schedule

Survey #	Survey Dates (2018)
1	June 17 – June 18
2	June 30 – July 1
3	July 14 – July 15
4	July 29 – July 30

2.2 Project Action Area

The action area for the proposed project is defined as “all areas to be affected directly or indirectly by the proposed action and not merely the immediate area directly adjacent to the action” (50 CFR §402.02). Project components that pose potential effects include construction noise, sedimentation and turbidity downstream during construction activities in the river channel, clearing and grading resulting from construction activities, and operation of the bridge.

2.2.1 Aquatic Portion of the Action Area

The aquatic portion of the action area is defined by the furthest extent of effects anticipated as a result of instream work. Instream work for both the construction of the new South Avenue Bridge and demolition of the Maclay Bridge will likely involve the use of pile driving and isolation of work areas by installing coffer dams. This would produce the greatest impact extent from underwater noise. Ambient underwater noise has not been measured at the bridge location, but can be estimated from river characteristics. Ambient noise levels in deep freshwater lakes or deep slow moving rivers are approximately 135 dB RMS and in shallow (1 foot deep or less), fast moving rivers, the ambient noise levels are louder and are approximated to 140 dB RMS in these systems (Laughlin 2005 as cited in WSDOT 2015).

The size and type of pile affect the amount of sound generated by pile-driving activities. Current design for the proposed bridge anticipates the use of 16 to 24 inch diameter steel piles for the pier foundations depending on final geotechnical recommendations. Studies conducted by the Washington State Department of Transportation (WSDOT) report underwater noise levels for 24 inch steel piles at 189 dB RMS measured at 33 feet from the pile. Using the practical spreading model (WSDOT 2015) and 135 dB ambient for a flowing river, if sound from the impact pile driving was unimpeded through the water, it would not dissipate to ambient levels until approximately 24 miles. However, underwater noise propagation in rivers is limited by the sinuosity of a system and generally dissipates at river bends, beyond line-of-sight (WSDOT 2015). The Bitterroot River bends to the west downstream of the Maclay Bridge. This bend in the river would disrupt the propagation of the underwater noise where it curves out of line-of-sight at approximately 1,200 feet downstream from the proposed construction location where piles would potentially be installed for work trestles to facilitate demolition of the existing bridge.

Upstream of the proposed South Avenue Bridge site, the river bends around to the east and out of line-of-site at approximately 3,300 feet. Noise effects from pile driving for the bridge piers would dissipate at these distances and these form the upstream and downstream boundaries of the aquatic action area for the project. Due to the shallow water levels in O'Brien Creek as well as its small size and sinuosity, underwater noise effects from pile driving would not propagate beyond the mouth and first bend in O'Brien Creek less than 100 feet from the confluence with the Bitterroot River. If drilled shaft pier installations are used, sound impacts underwater would be reduced due to lower decibel (dB) levels produced from that construction method, but the line-of-sight upstream and downstream aquatic action area boundaries would remain the same since these distances are less than the distance underwater construction noise would propagate.

Temporary sediment and turbidity induced from instream work during construction of the piers for the new bridge, and pier removal for the Maclay Bridge is anticipated to dissipate within the downstream extent of the noise impacts as the river bends to the west downstream of the existing Maclay Bridge site during removal of the piers. Work in the river would occur within the in-water work window when summer low flows generally occur. Cofferdams would be used to isolate work areas around the piers in the river channel and reduce downstream turbidity effects to periods of coffer dam installation and removal.

The presence of the proposed bridge piers within the river channel could alter hydraulics downstream. The size of the piers are small in relation to the river at the bridge crossing location, therefore any hydraulic effects would be expected to dissipate over relatively short distances. Because noise impacts are expected to dissipate to background levels in the river around 3,300 feet upstream of the proposed bridge site and approximately 1,200 feet downstream of Maclay Bridge, beyond any turbidity or hydraulic effects, the aquatic portion of the action area would be determined by noise impacts (Figure 2-1).

2.2.2 Terrestrial Portion of the Action Area

The terrestrial portion of the action area is defined based on the potential for noise associated with operation of construction equipment. The locations of the construction contractors' staging and equipment areas are unknown at this stage in the project, but these sites would be located in existing ROW and previously disturbed areas along existing roadways and agricultural fields landward of riparian areas. Baseline noise levels for the project site were assumed to be about 55 dB based on the rural character of the area (WSDOT 2015).

The loudest equipment potentially used for this project could be an impact pile driver for the installation of the bridge piers. According to WSDOT (2015), impact drivers can produce peak decibels of 110 dB (in-air) as measured 50 feet from the device. Decibel addition rules are not applicable since noise associated with the next loudest noise-producing equipment anticipated to be used (excavator 81dB) differs by more than 10 dB when compared to the vibratory driver. Using a point-source sound attenuation model where a 6 dB noise reduction occurs per doubling distance from the activity, with an additional 1.5 dB of reduction due to soft site characteristics in the study area, noise should attenuate to baseline levels approximately 7,925 feet from the proposed bridge crossing when pile driving is being used. Topography and site characteristics affect the propagation of sound. For example, the hills located to the southwest of the project site would reduce the extent of noise in that direction. However, for this analysis a simplified uniform distance was used as a conservative area to assess potential impacts. Therefore, the terrestrial portion of the action area extends 7,925 feet (1.5 miles) in all directions from the proposed South Avenue Bridge and the existing Maclay Bridge locations (Figure 2-1).

The area within which surveys were conducted (YBCU study area) is defined by a one mile buffer of the collective Maclay Bridge and proposed new bridge site. The study area extent was requested by the USFWS staff because construction-related noise would be high enough (approximately 60 dB) to potentially disturb YBCU in the area. Construction-related noise might be heard by YBCU within the larger terrestrial action area beyond the YBCU study area. However, the noise levels outside of the study area are unlikely to disturb YBCU to the point of causing changes in normal behavior.

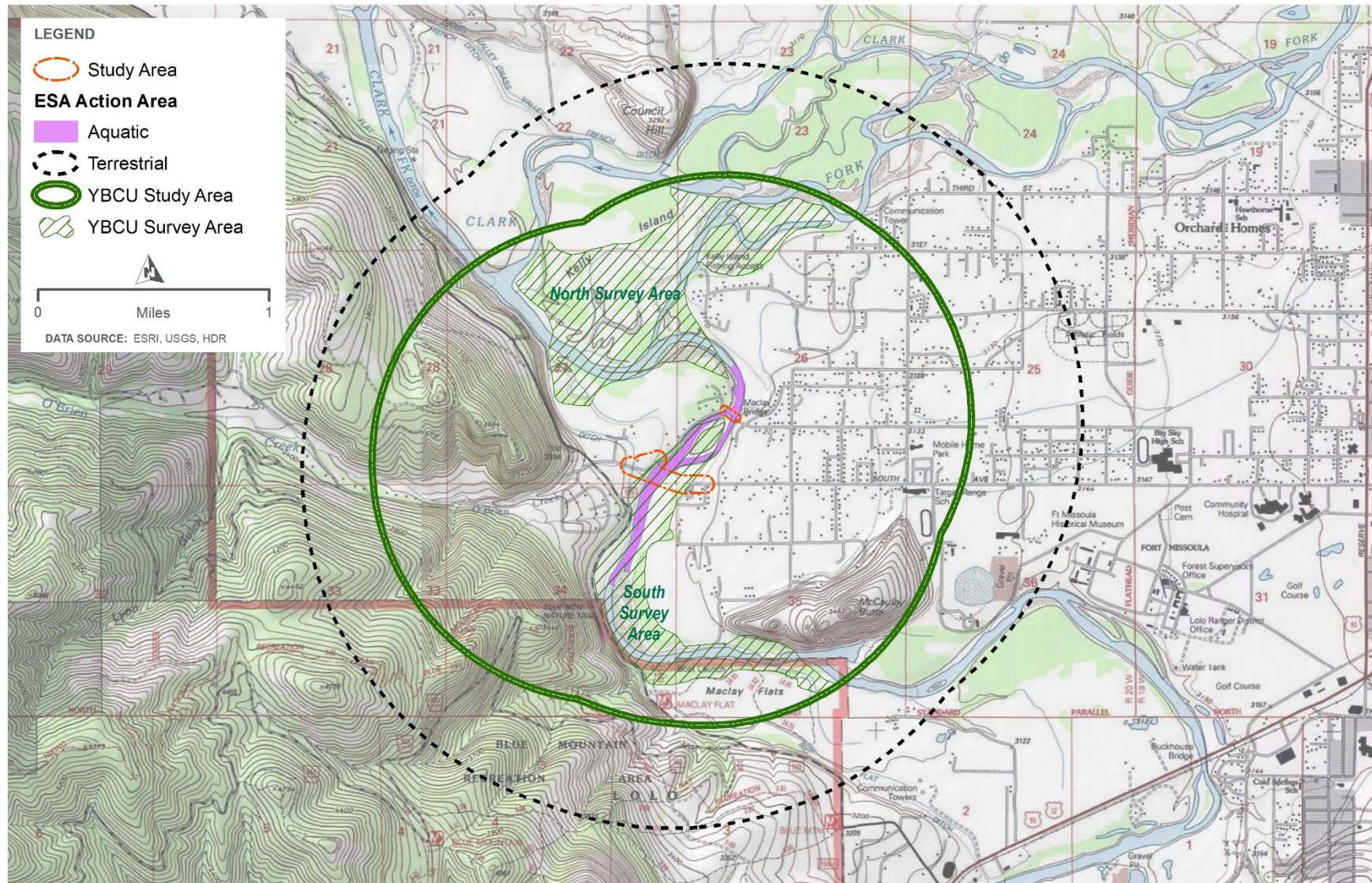

Figure 2-1. Project Action Area

3 Threatened and Endangered Species Biological Assessment

Section 7 of the Endangered Species Act (ESA) [16 U.S.C. 1531 *et seq.*] outlines the procedures for Federal interagency cooperation to protect federally listed species and conserve designated critical habitats. Section 7 requires Federal agencies to determine the effects of the proposed action on threatened, endangered, and proposed species and to consult with the USFWS for concurrence on the determination of effect. This section provides the Biological Assessment of the proposed action’s effect on federally listed species and designated critical habitats.

Federally-threatened, endangered, proposed and candidate species potentially occurring in Missoula County are listed in Table 3-1 along with their respective federal status. There are six federally listed species, one proposed species, and one candidate species with the potential to occur in Missoula County.

Table 3-1. Federally Listed Species Occurring in Missoula County, MT

Common Name	Scientific Name	Status ^a
Whitebark Pine	<i>Pinus albicaulis</i>	C
Canada Lynx	<i>Lynx canadensis</i>	LT, CH
Bull Trout	<i>Salvelinus confluentus</i>	LT, CH
Yellow-billed cuckoo (western pop.)	<i>Coccyzus americanus</i>	LT
Water Howellia	<i>Howellia aquatilis</i>	LT
Grizzly Bear	<i>Ursus arctos horribilis</i>	LT
Wolverine	<i>Gulo gulo</i>	P
Red Knot	<i>Calidris canutus rufa</i>	LT

Sources: USFWS 2018a

^a C = Candidate; CH = Designated Critical Habitat; LT = Listed Threatened; P = Proposed

Based on review of federal, state, and local agency databases (FWP 2016; StreamNet 2016; NOAA 2016), there are no species or critical habitat under the purview of NMFS that are expected to occur in the action area.

The following sections provide additional information on the species listed in Table 2-1. Of these species, only bull trout (and bull trout critical habitat) and yellow-billed cuckoo have potential to occur within the action area and therefore greater detail is provided below for each of these species.

3.1 Previous Effect Determinations in the Preliminary Biological Assessment

Due to lack of occurrence and suitable habitat for several of the species identified in Table 2-1, it has been determined that the proposed project would have no impact on these species. The Preliminary Biological Assessment completed in January 2017

rendered a **no effect** determination with regard to the federally listed threatened and endangered species that include Canada lynx, water howellia, grizzly bear, and red knot. The proposed project was determined as **not likely to jeopardize the continued existence** of the whitebark pine and wolverine. A **may affect** was rendered with regard to the bull trout and bull trout critical habitat and yellow-billed cuckoo. The proposed project's potential effect on bull trout, bull trout critical habitat, and yellow-billed cuckoo is the focus of this BA.

3.2 Bull Trout

3.2.1 Status and Life History

The USFWS defined a single DPS for bull trout (*Salvelinus confluentus*) within the coterminous United States and listed them as threatened under the ESA in 1999 (64 FR 58910). This single DPS is subdivided into six biologically-based recovery units, of which the Columbia headwaters recovery unit contains the Bitterroot River population (USFWS 2015b).

Bull trout occur in nearly all of the Columbia River Basin in higher elevation tributaries in Washington, Oregon, Idaho, Montana, and a small part of Nevada. The historical range of bull trout includes major river basins in the Pacific Northwest at about 41 to 60 degrees North latitude, from the southern limits in the McCloud River in northern California and the Jarbidge River in Nevada to the headwaters of the Yukon River in the Northwest Territories, Canada (Cavender 1978). Although bull trout are presently widespread within their historical range, they have declined in overall distribution and abundance during the last century. Dams, forest management practices, agriculture, roads and mining are primary land and water management activities that threaten bull trout and degrade its habitat (USFWS 1998a). In addition, native bull trout have been displaced in many areas through competitive interaction with introduced brook trout. Bull trout and brook trout can interbreed and the offspring are sterile hybrids, further contributing to bull trout population decline (FWP 2015).

Bull trout express both resident and migratory life history strategies (Rieman and McIntyre 1993). Resident forms of bull trout complete their entire life cycle in the tributary (or nearby) streams in which they spawn and rear. Migratory bull trout spawn in tributary streams, where juvenile fish rear for 1 to 4 years before migrating to either a lake (adfluvial form) (Downs et al. 2006), river (fluvial form) (Fraley and Shepard 1989), or in certain coastal areas, to saltwater (anadromous) (Cavender 1978, McPhail and Baxter 1996; Brenkman and Corbett 2005). Bull trout have more specific habitat requirements than most other salmonids (Rieman and McIntyre 1993) and require very cold water for spawning (46 °F) and egg incubation (below 40 °F). High-quality spawning and rearing habitat is typically characterized by cold temperatures; abundant cover in the form of large wood, undercut banks, and boulders; clean substrate for spawning; intergravel spaces large enough to conceal juveniles; and stable channels (USFWS 2015b). Spawning areas are often in headwater streams and associated with coldwater springs, groundwater infiltration, and the coldest streams in a given watershed (USFWS 2015a; Rieman and McIntyre 1993).

Bull trout reach sexually maturity in 4 to 5 years. Spawning takes place between late August and early November, principally in third and fourth order streams. Bull trout prefer spawning habitat in low-gradient stream reaches with loose, clean gravel (Fraley and Shepard 1989) and do not tolerate high sediment levels in their spawning streams. Sediment can suffocate the developing embryos before they hatch.

3.2.2 Occurrence in Action Area

The reach of the Bitterroot River within the project action area is known to be occasionally used by bull trout for overwintering, is a migratory corridor, and has been designated as a critical habitat for the species, and serves as foraging, migratory, and overwintering (FMO) habitat (Mike McGrath, USFWS pers. com. Aug. 12, 2015; StreamNet 2016). The project action area and surrounding lower mainstem of the Bitterroot River does not contain bull trout spawning or rearing habitat, and is well known as being too warm for bull trout in the summer (Ladd Knotek, FWP pers. com. July 23, 2015). O'Brien Creek is the only perennial tributary in the project reach of the Bitterroot River, and its mouth can serve as a cold water refuge for bull trout and other fish species in summer months (Mike McGrath, USFWS pers. com. Aug 12, 2015a). While the creek mouth may act as a temperature refuge or winter foraging area for adults, O'Brien Creek is not used by bull trout for spawning or rearing (FWP 2016; StreamNet 2016).

Bull trout spawning is reported to occur in headwater tributaries, and the closest documented spawning stream is Skalkaho Creek (Ladd Knotek, FWP pers. com. July 23, 2015), located over 50 river miles upstream of the action area. Due to bull trout juveniles' propensity to remain in tributary habitats near their spawning grounds, it is unlikely that juveniles would be rearing or present in the action area. Bull trout use of river habitat is limited by a preference for cooler water temperatures and they avoid areas that reach or exceed 15° C (Fraley and Shepard 1989; Bjornn and Reiser 1991). Water temperature data from the Bitterroot River at the closest USGS gage station about 3.5 miles upstream of the project site (USGS station 12352500) indicates that preferred temperature is typically exceeded between July 1 and September 1 most years. As a result, bull trout may seek refuge in cooler tributaries during this time period, which coincides with the typical instream work window for the Bitterroot River from July 1 through September 30.

3.2.3 Bull Trout Critical Habitat

On October 18, 2010, the USFWS issued a final rule designating critical habitat for bull trout in the conterminous United States (75 FR 63898-64070), and recently developed implementation plans for the final bull trout recovery plan (USFWS 2015b, 2015c). The Bitterroot River and O'Brien Creek are included within designated critical habitat for bull trout (Unit 31 Clark Fork River Basin) as part of the Columbia Headwaters Recovery Unit. In freshwater areas, bull trout critical habitat includes the stream channels within the designated stream reaches and a lateral extent as defined by the bankfull elevation on one bank to the bankfull elevation on the opposite bank, or the OHWM if bankfull elevation is not evident on either bank (USFWS 2010a).

Critical habitat consists of physical and biological habitat features (PBFs) essential for the conservation of a species. The action agencies for this BA recognize that the USFWS and NMFS have removed the term "primary constituent elements" or "PCE" from designated critical habitat regulations (50 CFR 424.12) and have returned to the

statutory term “physical or biological features” (PBFs) (79 FR 27066). Considering this, the previous term, PCE, would be replaced hereforth with PBF to describe the physical and biological features that define critical habitat for listed species (81 FR 7214). As noted in 81 FR 7214, “the shift in terminology does not change the approach used in conducting a “destruction or adverse modification” analysis, which is the same regardless of whether the original designation identified primary constituent elements, physical or biological features, or both. Within designated critical habitat, the PBFs) for bull trout are those habitat components that are essential for the primary biological needs of foraging, reproducing, rearing of young, dispersal, genetic exchange, or sheltering. The following important PBFs are discussed below in relation to the proposed action.

PBF 1: Springs, seeps, groundwater sources, and subsurface water connectivity (hyporheic flows) to contribute to water quality and quantity and provide thermal refugia.

Development in the areas around the project reach roadways, existing Maclay Bridge, and associated bank rip rap has degraded floodplain function and connectivity and loss of overbank flow maintenance. Much of the surrounding area in the Bitterroot valley is used for agriculture, which relies heavily on irrigation from river water. Some irrigation water might eventually return to the river as groundwater. Based on this condition, the presence of springs, seeps, or groundwater sources or subsurface water connectivity to these water sources is degraded and somewhat lacking in the action area.

PBF 2: Migration habitats with minimal physical, biological, or water quality impediments between spawning, rearing, overwintering, and freshwater and marine foraging habitats, including but not limited to permanent, partial, intermittent, or seasonal barriers.

There are no physical barriers in the Bitterroot River from its confluence with the Clark Fork River upstream through the project site. High instream temperatures during the summer months of July and August may constitute a thermal barrier to migration and use. Temperature barriers to rearing and migration may be present if stream temperatures exceed 12°C and 15°C (54 to 59 °F), respectively (USFWS 1998a).

PBF 3: An abundant food base, including terrestrial organisms of riparian origin, aquatic macroinvertebrates, and forage fish.

This PBF is present and functioning in the action area FMO habitat. Other species of fish described in Section 3.2, including rainbow trout and cutthroat trout, occur in the action area (Knotek 2005) and provide forage fish species for subadult and adult bull trout (FWP 2016). Data on aquatic macroinvertebrates is unavailable, though benthic macroinvertebrates are certainly present to some degree in the action area.

PBF 4: Complex river, stream, lake, reservoir, and marine shoreline aquatic environments, and processes that establish and maintain these aquatic environments, with features such as large wood, side channels, pools, undercut banks and unembedded substrates, to provide a variety of depths, gradients, velocities, and structure.

While present, this PBF is degraded in the action area. The project reach of the Bitterroot River is a single channel at the bridge site and splits to include a side channel downstream of the proposed bridge site. Large woody debris and instream channel habitat structure is lacking. The mouth of O'Brien Creek is located just upstream of the proposed bridge site on the left bank and associated scour pool.

PBF 5: Water temperatures ranging from 2° to 15 °C (36 to 59 °F), with adequate thermal refugia available for temperatures that exceed the upper end of this range. Specific temperatures within this range will depend on bull trout life-history stage and form; geography; elevation; diurnal and seasonal variation; shading, such as that provided by riparian habitat; streamflow; and local groundwater influence.

This PBF is present, but not properly functioning in the summer months in the action area. The lower Bitterroot River mainstem exhibits high summer temperatures that reach 20 °C during much of July and August (USGS station 12352500 data). It is unknown to what degree that flow and habitat modification have contributed to these warm thermal regimes, but it is likely that these modifications have warmed the lower river relative to historic conditions. Temperatures during the later fall, winter and spring do not prohibit bull trout use through this reach.

PBF 6: In spawning and rearing areas, substrate of sufficient amount, size, and composition to ensure success of egg and embryo overwinter survival, fry emergence, and young-of-the-year and juvenile survival. A minimal amount of fine sediment, generally ranging in size from silt to coarse sand, embedded in larger substrates, is characteristic of these conditions. The size and amounts of fine sediment suitable to bull trout will likely vary from system to system.

This PBF is not present in the action area. The action area reach does not support bull trout spawning, possibly attributed to prohibitively high instream temperatures during the September spawning period.

PBF 7: A natural hydrograph, including peak, high, low, and base flows within historic and seasonal ranges or, if flows are controlled, minimal flow departure from a natural hydrograph.

This PBF is degraded in the action area. Channelization, agriculture and residential development have altered the natural hydrograph of the lower Bitterroot River mainstem. Irrigation withdrawals and runoff influence flow levels in the lower Bitterroot River mainstem and impair the natural hydrograph.

PBF 8: Sufficient water quality and quantity such that normal reproduction, growth, and survival are not inhibited.

This PBF is impaired in the action area. The Bitterroot subbasin has a number of water quality issues, mostly related to non-point sources of pollutants, alteration of channels, and water withdrawals. Sediment, nutrients, and temperature are three of the most commonly cited water quality issues for the mainstem of the Bitterroot River and some tributary streams. The reach of the Bitterroot River in the project vicinity is on the 303(d) list of impaired waters (DEQ 2016). Temperature, runoff, agriculture, habitat modification, and wet weather discharges in the contributing basin are the primary sources of impairment.

PBF 9: Sufficiently low levels of occurrence of nonnative predatory (e.g., lake trout, walleye, northern pike, smallmouth bass); interbreeding (e.g., brook trout); or competing (e.g., brown trout) species that, if present, are adequately temporally and spatially isolated from bull trout.

This PBF is impaired in the action area. Brook and rainbow trout, both introduced to the Clark Fork Basin, are present in the action area.

3.2.4 Potential Impacts on Bull Trout and Bull Trout Critical Habitat

Construction of the project is anticipated to occur within two seasons, with construction of the new bridge occurring in year one and removal of the Maclay Bridge in the second year. Work within the river would be scheduled to occur during the summer in-water work window (July 1 and September 30) when bull trout are least likely to be present.

Potential impacts from the proposed project would be attributed to construction activities for the new South Avenue Bridge and removal of the existing Maclay Bridge. The main components of construction that could impact bull trout are related to noise disturbance, impacts on habitat, and potential for sedimentation or hazardous materials downstream.

Although instream work can have potential for direct mortality of bull trout during construction activities by killing adult or juvenile fish and/or incubating eggs within spawning areas, there is no suitable spawning habitat in the lower Bitterroot River in or near the action area. Therefore no direct mortality of incubating eggs or destruction of redds is anticipated. Instream project activities including pile driving could result in mortality or injury to adult and subadult bull trout. Pile driving could be used for the installation of piers, coffer dams, and pilings associated with work bridges and the new bridge. Although the chance of the project causing direct mortality of individual bull trout is remote due to the extremely low population density, the chance does exist.

Underwater Noise

Construction-generated underwater noise, particularly noise related to impact pile driving, has the potential to injure or kill fish, depending on the duration and magnitude of the noise, and the size of the fish. Impact pile driving creates high sound pressure waves that can result in physical damage including hemorrhage and rupture of the gas-filled internal organs of fish such as swim bladders, eyes, and kidneys (Turnpenny et al. 1994; Popper 2003; Hastings and Popper 2005). Depending on the source of such underwater sound pressure levels, the disturbance can also result in temporary stunning of fish, and alterations in behavior that could potentially affect fish feeding and predator evasion within the vicinity of the pile-driving activity (Turnpenny et al. 1994; Popper 2003; Hastings and Popper 2005).

Based on NMFS noise thresholds for harm and injury, peak noise levels at or above 206 dB may harm fish. Cumulative noise levels above 183 dB are considered to put fish less than 2 grams in size at risk of injury or death, while levels above 187 dB may harm fish greater than 2 grams in size (WSDOT 2015). Fish behavior may be modified at about 150 dB (WSDOT 2015). These noise thresholds for harm and behavioral modification are primarily based upon underwater noise levels produced during impact pile driving. As described above, this impact analysis assumes that impact pile driving would be the method used to install the bridge piers, although vibratory installation of steel casing and drilled shafts remains a possible method.

Vibratory installation would result in less noise and therefore reduced impacts on fish because generated sound pressures would not approach injury levels for fish larger than 2 grams in size (i.e., the size class of bull trout with greatest potential to be present in action area). Regardless, vibratory installation of piles is typically followed by final proofing using an impact hammer.

If bull trout are present within the immediate study area during pile driving activities, they could be susceptible to mortality or injury. However, installation of the bridge piers, associated cofferdams and work trestles in the river channel would occur within the in-water work window when bull trout would not be expected to be present due to high summer water temperatures as previously described. Further, in the unlikely event that bull trout are present, shallow water during the summer work window in both the Bitterroot River and O'Brien Creek would reduce the propagation of underwater noise impacts. A study on pile driving noise in the Yakima River in Washington concluded that 24 inch steel piles driven with an impact hammer in shallow, flowing water had sound levels inhibited due to the shallow water and did not exceed thresholds that would cause injury or mortality to fish (Laughlin 2005).

Construction activities conducted prior to initiating impact pile driving, including instream excavation and the potential use of vibratory hammers for preliminary pile installation could expose any fish to underwater noise. However, such noises are highly unlikely to produce sound pressure levels that would elicit an avoidance response by fish. Further, as previously described, the potential for bull trout to be present in the action area during the summer in-water work window is remote.

Construction noise associated with Maclay Bridge removal could also expose fish to underwater noise. No blasting is anticipated to be required for the demolition of Maclay Bridge; however, regardless of the contractor method of pier removal, some noise will occur. The piers to be removed at Maclay Bridge are located on vegetated gravel bars and not within the main river channel. In-water construction activities at Maclay Bridge would occur during the in-water work window. Due to construction timing during low flows it is unlikely that fish would be present in the vicinity. Isolation of the work area would further reduce underwater noise and it is highly unlikely that construction noise would produce sound pressure levels that would elicit an avoidance response by fish.

Sedimentation and Turbidity

In-water construction for the installation for the bridge piers, coffer dams, and work trestles, as well as the placement of west bank rip rap would result in sedimentation and turbidity downstream of the proposed crossing. In-water work for removal of the bridge piers for Maclay Bridge would also result in suspended sediment and turbidity downstream of that site. The installation of sheet pile coffer dams would isolate the work areas for pier removal and reduce the amount of sediment introduced into the river during construction and demolition activities.

Bridge deck removal for Maclay Bridge is another potential source of instream disturbance as contractors may not be able to capture and contain all fine materials that could enter the river. This impact is expected to be minor, as the contractor will be required to contain anticipated materials. Section 208 of the MDT *Standard Specifications for Road and Bridge Construction* specifies the process with which the contractor must comply to prevent and control the siltation of lakes, streams, rivers, ponds, and other wetlands.

Although sedimentation and elevated turbidity can affect fish behavior, physiological processes (e.g., gill function), and prey resources, bull trout are highly unlikely to be present in the action area during the instream work window. Further, no bull trout spawning is known to occur in the vicinity or downstream of the proposed bridge

crossing, and spawning habitat is not present in the mainstem reach. Sedimentation and turbidity from in water construction activities would not impact bull trout spawning habitat.

Although bull trout are not expected to be within the action area during in-water construction due to high stream temperatures in the summer, in the unlikely event that any individuals are present, they would be mobile adults or subadults. Such lifestages would be able to move away into adjacent undisturbed areas upstream or downstream and avoid any temporary sediment plumes associated with construction or bridge removal activities.

Increased turbidity and sedimentation downstream of the project could negatively affect benthic macroinvertebrate prey items by altering water quality and/or substrate. However, benthic species are expected to recover rapidly after construction and organisms that occur in the drift, such as mayflies, caddisflies, and midge larvae, would be able to quickly recolonize the affected area (Reid et al. 2002). These temporary impacts on the food web would have minimal if any effect on bull trout, which only intermittently occupy the action area as adults that feed on other smaller fish and not typically benthic invertebrates.

Fish Passage and Aquatic Habitat Modification

Construction activities along the river banks and at the piers in mid channel would not fully span the river channel. Therefore, in the unlikely event that bull trout were present, they could pass through the action area unimpeded. Noise and turbidity may deter fish from using the area during construction as described above; however, few, if any, bull trout would be expected in the construction area during the summer work window.

The placement of concrete block or similar structured cofferdams for instream work isolation for the bridge piers would result in modifications to localized channel morphology. The reduction in river habitat available to bull trout in the affected reach and the alteration of local flow patterns would be temporary in nature and, following construction, would be returned to pre-project conditions. However, as previously discussed, with the possible exception of a few transitory adults or subadults, bull trout are highly unlikely to be present during the instream work window, therefore, it is not anticipated that fish salvage would be required in areas to be dewatered for instream work.

The placement of new bridge piers within the river channel would result in minor, localized hydraulic modifications in the action area, and minor modifications to channel morphology. The current design of the proposed bridge includes two pier foundations of approximately 830 square feet each. The size of the piers is small in relation to the river and any hydraulic effects would be expected to dissipate over relatively short distances. Some scour of the river bed is anticipated at higher flows from the proposed piers. Because the action area is primarily utilized as a migratory corridor for bull trout, it is unlikely that minor localized modifications to hydraulic patterns would affect the ability of bull trout to migrate through the reach and around hardened structures.

Long-term degradation of aquatic habitats could occur if the disturbed stream channel is not restored to a stable and functional condition. For example, modification of stream contours could lead to channel incision and loss of floodplain connection. Erosion of the streambed, banks, or adjacent upland areas could also introduce sediment into the waterbody. Streambank modification and loss of riparian vegetation along the banks

could also decrease existing root stock that stabilizes banks. No channel grading is proposed for the bridge project, and bank modifications will largely be avoided. A minor amount of stabilizing rip rap will be placed at the west abutment outside of the main river channel. The east abutment for the new bridge would remain above the OHWM (see Preliminary Bridge Layout Plan in Appendix C). The existing banks in the project footprint are not undercut, and no large woody debris was present during the field visit, and none would need to be removed for the proposed project. The river bank modification is also small, at well below 0.5 acre, compared to available natural banks on both sides of the river upstream and downstream of the project footprint. Impacts on stream habitat would result in insignificant effects on species use of the migratory corridor.

Removal of the existing Maclay Bridge, including bridge piers and abutments, will permanently alter the stream morphology at this location by restoring a normal cross-sectional width for this reach and benefit the floodplain by removing the current restrictive infrastructure. Removal of the Maclay bridge piers would also off-set the loss of river substrate habitat resulting from the installation of the new piers for the proposed bridge.

Riparian Vegetation Removal

Riparian vegetation clearing would be necessary within the project construction footprint of the new bridge as well as a small area of vegetated gravel bar surrounding the piers to be removed at Maclay Bridge. In addition, minor temporary vegetation clearing may be necessary on the east bank at Maclay Bridge to provide equipment access. Riparian vegetation removal could impact bull trout and bull trout critical habitat via loss of instream shading and a reduction of large woody debris. On the west bank at the new bridge site, the project would avoid impacting riparian vegetation around the mouth of O'Brien Creek, but would impact tree cover within the permanent project footprint on the west bank, north of the creek. The permanent footprint is anticipated to remove approximately 0.3 acre of riparian vegetation on the right and left banks immediately adjacent to the Bitterroot River. This would result in a small, localized loss of potential large woody debris input and bank cover, but would be insignificant compared to that available upstream and downstream. Permanent removal of native vegetation would be limited to the extent practicable to construct the project and thus is not anticipated to have a long-term negative impact to overall riparian habitat along the Bitterroot River.

Restoration through planting of riparian species would occur where practicable in disturbed areas adjacent the Bitterroot River following construction of the South Avenue Bridge and removal of Maclay Bridge. The abandoned segments of River Pines Road will be obliterated: asphalt removed, re-graded, and revegetated to provide for developing additional riparian buffer for mitigation between the west roadway approach and O'Brien Creek.

Introduction of Hazardous Materials

Petroleum products and wet concrete are two items that have potential to negatively impact bull trout, in the unlikely event that individuals are present in the action area during in-water work. Potential sources of fuel and oil spills include heavy equipment, portable water pumps, or products stored on site throughout the duration of the project. Specific minimization measures have been established regarding fuel storage, fueling of equipment and spill containment, including provisions for contractor preparation of spill

prevention plans. These measures should reduce or eliminate the potential for spill events, and thereby reduce or eliminate any effects on bull trout.

Wet concrete, if placed directly in contact with live stream water, can increase pH and release carbonate, both of which are toxic to fish under certain conditions. Installation of the instream pier would be accomplished in an isolated work area with the use of either a coffer dam to install steel piles or steel casing to install drilled shafts. Installation of either method would isolate the concrete footing and pier from the stream and prevent exposure of the stream to any concrete. Materials excavated from inside the coffer dam work area or drilled shaft casing would not be permitted to enter the river. All water from inside the drilled shaft casing would be required to be pumped to collection areas on the stream bank.

Prior to and during construction, MDT will be required to acquire and comply with various state and federal water quality permits in association with this project. These include a Stormwater Pollution Prevention Plan (SWPPP) to be filed with DEQ and USACE Clean Water Act (404/401) permits and certifications. BMPs as described below in the Recommended Conservation Measures section would be used to prevent runoff or materials from construction of the abutments on each bank from entering the river.

Operation

Operation of the bridge would have minimal impacts as the area is already developed and the proposed bridge would replace the existing Maclay Bridge. The proposed structure has been designed to minimize any need for future in-water maintenance activities.

The new bridge will be designed to prevent stormwater runoff, including deicing chemicals, and road debris from directly entering the Bitterroot River. Deck drains will be required on the new bridge but will be located so no runoff drains directly into the river, and stormwater will be conveyed to areas inland of each bank for natural infiltration. The current approach is to convey stormwater from the bridge away from the active river channel and dispense onto the east overbank. Specific stormwater facilities have not been determined at the current level of design but will take floodplain inundation into consideration and would avoid impacts from stormwater on O'Brien Creek through protective vegetated buffers and grading restored areas to slope away from O'Brien Creek where possible.

The piers for the proposed bridge will be designed to incorporate scour protection and stream function is anticipated to remain unchanged for sediment transport capacity, channel stability, and width-to-depth ratio. The proposed project should not have any long-term effects on water quality and long-term stream function or hydrology, nor will it deter fish such as bull trout from returning to this reach of the river once the project and all construction activities are complete.

Impacts to Bull Trout Critical Habitat

Impacts on each of the PBFs from the construction and operation of the proposed project and demolition of Maclay Bridge on bull trout critical habitat have been previously described. The project would have no effect on PBF 1 because installation of the new bridge piers and removal of Maclay Bridge would not alter groundwater sources or hyporheic flows or connectivity to these water sources. PBF 2 would also not be affected

by the project as migratory passage would be maintained, including during construction since coffer dams and pier footprints do not span the river and upstream and downstream passage would be maintained throughout.

PBF 3 could be minimally impacted during construction of the instream piers, and pier removal at the existing bridge from temporary loss of macroinvertebrate habitat. These impacts would be temporary and minimal due to lack of juvenile bull trout rearing in the area, and areas of the streambed that would be impacted are small relative to the size of the river in the action area. Potential minor impacts to PBF 4 could also occur due to minor alteration of the existing riverbed at the pier sites, and bank alterations at Maclay Bridge. Complex river habitat including pools and large woody debris, however, is lacking in the action area and impact on these features is not anticipated.

Bridge construction and removal of Maclay Bridge would cause temporary turbidity during instream construction activities, notably during coffer dam installation and removal as described above. This would produce minor, temporary impacts to PBF 8 in terms of water quality, but water quantity would not be affected.

The project would have no effect on PBFs 5, 6, and 7 since the flows and temperatures in the river would not be altered due to construction or operation of the project, and no bull trout spawning or rearing occurs in the action area. The project would also have no impacts on PBF 9, as the fish species composition in the action area would not be altered and competing or predatory species abundance would not be promoted.

3.2.5 Conservation Measures for Bull Trout

To minimize and avoid impacts to bull trout, the following language for conservation measures will be incorporated into the construction design and special provisions:

1. To minimize impacts to overwintering and migrating bull trout, impact pile driving for the construction of temporary and permanent facilities that has not been attenuated for noise will occur between July 1 and September 30. This work window includes dry land and in-water impact pile driving.
2. To minimize the risk of barotraumas and fish mortality from driving piles for construction of the new bridge and any temporary work bridges outside the above time period:
 - a. Use a vibratory hammer to drive piles to such point when an impact hammer will be required to drive the pile to the point of refusal OR;
 - b. Initiate impact hammer pile-driving of each pile with lower hammer strokes than are required for the initial six strikes to encourage fish to vacate the surrounding area, and use the National Marine Fisheries Service Stationary Fish SEL Calculator Tool to determine how many pile strikes can occur during a day, based on pile type and size, prior to the thresholds being attained. Once the number of strikes has been attained, impact pile driving must be stopped for the day. If driving pile with an impact hammer over consecutive days, do not drive piling between the hours of 9:00 PM and 6:00 AM. OR;
 - c. Use MDT-approved noise reduction methods, such as those offered in Leslie and Schwertner (2013) (e.g., bubble curtains, coffer dams) AND:

- d. Conduct hydroacoustic monitoring. Through hydroacoustic monitoring, should it be determined that the physical harm thresholds of the peak sound pressure level (SPL) of 206 dB (re: 1 μ Pa), or the cumulative sound exposure level (SEL) of 187 dB (re: 1 μ Pa) for fish > 2 g, or 183 dB (re: 1 μ Pa) for fish < 2 g have been attained or exceeded, impact pile driving must be stopped for the day, with impact pile driving permitted to commence the next morning.
3. To the maximum extent possible, disassemble the existing bridge and remove without pieces being allowed to fall into the stream. If portions of the old bridge do fall into the stream during demolition, they will be removed from the stream without dragging the material along the streambed, and will be removed within two days. No blasting is anticipated to be required for the demolition of Maclay Bridge.
4. Instream work conducted within the channel shall be kept to the minimum amount necessary, and within the in-water work window. This includes, but is not limited to, construction and removal of any coffer dams that may be needed for the driving and removal of pilings for any temporary support structures that may be necessary and riprap placement below the ordinary high water mark. Instream construction work shall be completed in the shortest amount of time possible.
5. Any temporary work or detour bridges necessary at these crossings should clear span the stream channel, if possible. No construction equipment would be allowed to operate within the active channel of any stream unless permitted to do so.
6. Do not allow materials excavated from inside any dewatering structures to enter any stream.
7. Ensure best management practices for erosion control are applied to this project, including, but not limited to:
 - a. Install and maintain appropriate BMPs to prevent erosion and sediment transport;
 - b. Reseed and revegetate all disturbed areas with desirable vegetation;
 - c. Stabilize disturbed channel banks using appropriate BMPs; and
 - d. Conduct work to minimize disturbance to riparian vegetation.
8. Collect and dispose of all waste fuels, lubricating fluids, herbicides, and other chemicals in accordance with all applicable laws, rules and regulations to ensure no adverse environmental impacts will occur. Inspect construction equipment daily to ensure hydraulic, fuel and lubrication systems are in good condition and free of leaks to prevent these materials from entering any stream. Locate vehicle servicing and refueling areas, fuel storage areas, and construction staging and materials storage areas to ensure that spilled fluids or stored materials do not enter any stream.
9. Structures designed to minimize sediment and pollutant runoff from sensitive areas such as settling ponds, vehicle and fuel storage areas, hazardous materials storage sites, erosion control structures, and coffer dams should be visually monitored daily, especially following precipitation events, to ensure these structures are functioning properly.

10. Monitor all dewatering activities visually to ensure bull trout are not trapped. In the unlikely event a bull trout is found within a dewatering area, return it immediately to the stream.
11. Any detention basin outlets will be designed such that they are stabilized to prevent streambank erosion and will not otherwise impact the stream channel bank.
12. The contractor will dispose of drill cuttings in areas in a manner which will not adversely affect federally listed species and/or designated critical habitat. Barge debris will be captured and/or contained to prevent material from entering the channel.
13. Upon locating dead, injured, or sick bull trout, notify the Missoula County Project Manager and contract the USFWS Field Office at (406) 449-5225 within 24 hours. Record information relative to the date, time, and location of dead or injured bull trout when/if found. Include any activities that were occurring at the location and time of injury and/or death of each fish and provide this information to the USFWS.

3.2.6 Determination of Effects

The reach of the Bitterroot River within the action area is used as a migratory corridor by adult and subadult bull trout moving between spawning habitats in upstream tributaries. Warm water temperatures in summer months most likely preclude bull trout from the project reach during late summer. Although occurrence of bull trout is low and not year round, there is the potential for individuals to be present within the project action area. For this reason a **may affect, likely to adversely affect** determination is rendered relative to bull trout.

Although the project reach of the Bitterroot River is designated as critical habitat for bull trout, the project reach is only intermittently used as a migratory corridor. Due to the relatively small footprint of the project on the river and riverbanks, and the removal of the existing Maclay Bridge, the effects of the project on critical habitat would likely be limited to temporary degradations to water quality. Because the project would take place in bull trout critical habitat, regardless of the level of impact on PBFs in the action area, a **may affect, likely to adversely affect** determination is rendered relative to bull trout critical habitat.

3.3 Western Yellow-Billed Cuckoo

3.3.1 Status and Life History

The western population of the yellow-billed cuckoo (*Coccyzus americanus occidentalis*) [YBCU] breeds along river systems west of the Rocky Mountains, which generally separate this population from its counterpart, the eastern yellow-billed cuckoo. Yellow-billed cuckoos breed throughout much of the eastern and central U.S., winter almost entirely in South America east of the Andes, and migrate through Central America. As long-distance, nocturnal migrants, YBCUs are vulnerable to collisions with tall buildings, cell towers, radio antennas, wind turbines, and other structures. However, YBCU population has decline by 1.6 percent per year between 1966 and 2010 is primarily attributed to the impacts to their riparian nesting habitat (USFWS 2018b). The YBCU

west of the Continental Divide has been identified by the USFWS as a Distinct Population Segment (DPS) which has been listed as threatened under the ESA since 2014 (79 FR 59991 60038).

The loss and degradation of native riparian habitat throughout the western YBCU's range have played a major role in the bird's decline. In the western states, much of the riparian habitat preferred by the YBCU has been converted to farmland and housing, leading to population declines and the likely extirpation of YBCU from British Columbia, Washington, Oregon, and Nevada (Hughes 2015). It is estimated that extensive suitable habitat in California supported 15,000 breeding pairs in the late 19th century, but habitat loss has significantly reduced the current breeding population to about 40 to 50 pairs (Hughes 2015). The YBCU is even rarer in the Northern Rockies, but is believed to potentially breed in southern Montana. Breeding populations in Idaho, Wyoming, Colorado, Utah, and Nevada are estimated at 5–20 pairs (Hughes 2015). Current nesting is primarily restricted to sites in Arizona and New Mexico where an estimated 300 nesting pairs occur (MTNHP 2018; Hughes 2015).

Throughout their range, preferred breeding habitat includes open woodland with thick undergrowth, parks, and deciduous riparian woodland. In the West, they nest in tall cottonwood riparian stands with willow understory (Hughes 2015). The western DPS typically requires relatively large, contiguous patches of habitat for nesting, consisting of at least 20 hectares (50 acres) or more of multi-layered riparian vegetation with a tree canopy and at least one layer of understory vegetation (Halterman et al., 2015). Nesting success is attributed to the quality and extent of suitable habitat along with availability and abundance of food resources (Halterman et al., 2015). Caterpillars and other large insects, as well as some frogs and lizards, comprise the main diet while fruit and seeds are also eaten, but more often on wintering grounds (Hughes 2015).

Nesting has not been recorded in isolated patches less than two acres or narrow, linear riparian habitats less than 10-20 meters wide (Halterman et al., 2015). However, individual birds have been detected in such isolated patches or linear habitats during migration or the early breeding season (mid-June) (Halterman et al., 2015). The western YBCU is a late season breeder, arriving on their breeding grounds 4 to 8 weeks later than eastern cuckoos (Hughes 2015). Most breeding western YBCU occur on their breeding grounds between mid-June and mid-September (Hughes 2015). In Montana, the YBCU has only been recorded to occur in June and July, and there has been no definitive evidence of breeding in the state (MTNHP 2018).

Migration and wintering habitat needs and patterns are not as well documented, although they appear to include a relatively wide variety of conditions. Migrating YBCUs have been found in coastal scrub, second-growth forests and woodlands, hedgerows, forest edges, and in smaller riparian patches than those preferred for breeding. Habitat in the wintering range includes open woodlands, evergreen gallery forest, thickets, semi-open scrub, forest edge, and occasionally mangroves (Halterman et al., 2015; Hughes 2015).

3.3.2 Occurrence in Action Area

Only eight sightings have been reported in western Montana since 1959. Of these, two sightings have been confirmed near the project vicinity and include (1) a female with an egg in the oviduct found in the Orchard Homes neighborhood in 1980, and (2) a single

bird that was photographed at 33 Marshall Street in Missoula in mid-June, 2012, and was potentially seen a few days later along Tower Street (USFWS 2015a). Despite the 1980 and more recent observations, the USFWS does not believe there is a breeding population of YBCUs in western Montana (USFWS 2015a).

Regionally, this species is considered a transient migrant in western Montana (USFWS 2015a). Suitable migratory habitat for the species occurs throughout the Missoula valley within riparian woodlands along streams and rivers. Two distinct sites containing suitable habitat in the action area were identified during the presence/absence survey of the project. The first site occurs along the Bitterroot River from about 50 meters south of the existing Maclay Bridge south to Maclay Flat Nature Trail (south survey site). The second site occurs on Kelly Island and adjacent peninsular landforms north of Maclay Bridge (north survey site).

The habitat within the two sites is composed of patches of riparian vegetation along the banks of the Bitterroot River and on Kelly Island. Much of the habitat is naturally bisected by the Bitterroot River or its floodplain channels, with some areas having been cleared for agriculture. The two sites in the YBCU study area are composed of mixed-native vegetation dominated by a black cottonwood (*Populus balsamifera*) overstory and an herbaceous understory, with an occasional shrubby willow (*Salix* spp.) understory.

The patches of riparian woodlands within the two survey sites contain about 40 percent or more canopy cover. These woodlands are dominated by black cottonwood with about 50 percent cover on average, but a shrub understory is absent in most woodlands. Less than 10 percent of suitable habitat within the study area contain both a dense shrub and canopy layer defining suitable YBCU nesting habitat.

The south survey site (about 80 hectares total) includes two-linear-miles of riparian habitat located south of the existing Maclay Bridge and within the floodplain of the Bitterroot River. Typical riparian woodlands within this site are characterized by a black cottonwood overstory averaging about 50 percent canopy cover with only an herbaceous understory layer in most areas. The area with the densest vegetation occurs within a linear strip of habitat between Blue Mountain Road and the western bank of the Bitterroot River. At about 6 hectares, this strip of habitat contains both a dense overstory of cottonwood and a dense shrub understory.

The north survey site (about 150 hectares total) has a similar mixed-native vegetation composition to the south survey site. This site's riparian woodlands have a similarly dense cottonwood overstory, fragmented by large grassland meadows and wide floodplain channels. Small, isolated patches (less than 5 hectares) occur that contain both a dense overstory and shrub understory, but these areas represent less than 10 percent (about 12 hectares) of the total survey site habitat.

The Bitterroot River experienced high runoff flows in the summer of 2018 due to higher than average winter snowfall. The high runoff resulted in the inundation of most floodplain channels in the YBCU study area. As a result, insect populations (particularly mosquitos and grasshoppers) responded to the higher water availability. Grasshoppers (Acrididae), a preferred YBCU food resource, were common during the last two surveys. Moths (Lepidoptera) and various aquatic insects were present throughout the survey. Tadpoles were also recorded during the first two surveys in ponded areas due to floodplain inundation. Due to these environmental conditions, food availability is not

expected to be a limiting factor to the YBCU occupancy of the study area. As a result, the 2018 season likely represents a higher than average probability for cuckoo to occur within the study area. **However, no YBCU were detected as a result of the protocol presence/absence surveys conducted in 2018 (Appendix A).**

Critical Habitat has been proposed for this species (79 FR 48547 48652), but critical habitat does not occur within the action area or anywhere within the state of Montana.

3.3.3 Potential Impacts on the Yellow-Billed Cuckoo

Due to the availability of suitable migratory habitat, there is the potential for a transient YBCU to occur in the action area. Potential impacts on the YBCU would be restricted to disturbance from in-air noise during construction and from a minor loss of suitable habitat during the removal of riparian vegetation for the proposed new bridge.

Effects from In-air Noise

The potential for disturbance from construction noise would be primarily limited the two months (June and July) when YBCUs have been recorded within the Missoula valley. Background noise levels were recorded during the YBCU survey to be between 55 and 60 dB. The most intense construction noise from pile drivers (110 db at 50 feet) would attenuate to 70 dB at 2,000 feet from the project area. As a result, approximately 300 acres (about seven percent) of the action area would experience noise levels at or above 70 dB. At about one mile from the project area, in-air noise levels from pile driving would fall below 60 dB which is considered the level above which could affect YBCU normal behavior.

The presence of YBCU in the action area during project activities could result in temporary affects to individual(s) from noise disturbance within a one-mile radius of the project area. However, these project activities would be limited in their duration (minutes to hours) and frequency (intermittently during the installation of the bridge piers). Any temporary disturbance to foraging individuals is expected to result in their dispersal into adjacent suitable habitat and avoidance of the action area during project activities. Affected YBCU are expected to resume normal behavior upon dispersal into suitable habitat outside of the action area. And, because only eight sightings have ever been recorded in western Montana since 1959, the chances of YBCU occurring in the action area are very low. Therefore, the number of YBCU likely to occur in the action area would not exceed more than a couple individuals, limiting the probability of effects to the species.

Effects to Suitable Habitat

The riparian vegetation on the eastern side of the existing Maclay Bridge is composed of a very narrow strip of low-growing sandbar willow (*Salix exigua*), herbaceous vegetation, and few second-growth cottonwood trees. This area does not contain suitable habitat, and therefore removal of the existing Maclay Bridge would not affect YBCU habitat. However, suitable riparian woodlands do occur along the proposed new bridge alignment which would be marginally impacted from construction.

Existing riparian vegetation in the proposed new bridge alignment is comprised of narrow bands of second-growth to mature black cottonwood, sandbar willow, and red osier dogwood (*Cornus sericea*). Construction of the new bridge would remove trees within the

permanent project footprint on the northern bank of O'Brian Creek. Other suitable foraging habitat (second growth vegetation) occurs along the eastern bank of the Bitterroot River in a narrow strip (about 30 meters wide) between the river bank and an open pasture. A third patch of mature woodland habitat within the footprint of the proposed new bridge, occurs directly adjacent to the terminus of South Avenue West.

The proposed new bridge would remove approximately 0.3 acre of suitable YBCU migratory habitat from the banks of the Bitterroot River. Permanent removal of native riparian vegetation would be limited to the extent practicable and revegetated where possible. Many hundreds of acres of riparian woodland habitat occur in the action area and within the surrounding Missoula valley. Considering to the extensive riparian habitat in the project vicinity, impacts to less than one acre of riparian habitat would be insignificant to the overall YBCU suitable habitat.

Restoration through planting of riparian species would occur where possible in disturbed areas adjacent to the Bitterroot River following construction of the South Avenue Bridge and removal of Maclay Bridge. At the Maclay Bridge, existing rip rap would be reinstalled following bridge abutment removal and in-stream habitat would be improved through vegetation restoration. The abandoned segments of River Pines Road will be removed and revegetated for additional riparian buffer between the west roadway approach and O'Brien Creek.

3.3.4 Conservation Measures for Yellow-billed Cuckoo

To minimize impacts on YBCU, the following conservation measures will be incorporated into the construction design and special provisions (USFWS 2015a):

1. To the extent possible, minimize the frequency and duration of project activities producing loud construction noise during the YBCU migratory and breeding season (June 1 through July 31) in Montana.
2. Adhering to the standard MDT MBTA vegetation removal special provision that requires clearing of trees and shrubs to occur between August 16 and April 15.
3. Minimize the removal of YBCU habitat (riparian woodlands).
4. Restore riparian vegetation where possible after construction is complete.

3.3.5 Determination of Effects

The historical presence of YBCU in the action area is extremely rare, and no YBCU were detected during the 2018 surveys. However, due to the recorded historical sightings and suitable migratory habitat in the action area, a low possibility remains for a transient bird to be present during construction activities in the summer months (June or July).

Project activities with the potential to affect yellow billed cuckoo include noise disturbance from construction activities and removal of about 0.3 acre of suitable riparian woodland habitat along the Bitterroot River.

The project *may affect* the western yellow-billed cuckoo by:

- Temporarily disturbing YBCU from construction noise and related project activities, resulting in their potential dispersal from and avoidance of suitable habitat in the action area.
- Removing or degrading YBCU suitable migratory habitat.

However, the proposed action is ***not likely to adversely affect*** the western yellow-billed cuckoo because:

- Western YBCUs are extremely rare in western Montana and therefore the potential frequency for occurrence is very low and the chances of disturbance to individuals in the action area is very unlikely. (discountable)
- The frequency, duration, and intensity of disturbance from noise levels in most of the action area would not rise to the level of harm or harassment that would result in altered behavioral patterns affecting reproduction or survival. (insignificant)
- Any disturbance to YBCU from noise or other project activity would at most result in the dispersal of foraging individuals into nearby suitable habitat (1 to 2 miles radius) of higher or equal quality. (insignificant)
- Any YBCU that occurs in the action area would very likely be a migrant(s), and consequently no breeding birds would be affected. (insignificant)

Based on the species' very rare historical record of occurrence and the lack of detections during the 2018 YBCU protocol survey, potential impacts from the proposed project would be insignificant and discountable; thereby warranting a ***may affect, not likely to adversely affect*** determination of effects to the yellow billed cuckoo.

Proposed critical habitat for the western YBCU does not occur within the action area, and therefore ***no effect*** will occur to critical habitat as a result of the project.

3.4 Potential Cumulative Effects Analysis

Cumulative effects include the effects of future state, tribal, local, or private actions that are reasonably certain to occur in the action area considered in this preliminary biological assessment (USFWS 1998b). Future federal actions that are unrelated to the proposed action are not considered in this section because they require separate consultation pursuant to Section 7 of the ESA (USFWS 1998b). A cumulative impacts analysis examines the additive effect of the proposed action's residual impact (i.e., impacts remaining after applying avoidance and minimization measures) in relation to the residual impacts generated by past, present, and reasonably foreseeable actions within the cumulative analysis area.

Residual impacts resulting from the proposed project include minor habitat loss for YBCU and short-term degradation of water quality in bull trout critical habitat. Other ongoing actions occurring in the cumulative analysis area that could influence habitat include private parcel development. Other ongoing actions occurring in the cumulative analysis area that could influence water quality include ongoing off-system road maintenance administered by the state and county, agricultural and grazing activities on rural

properties in the vicinity, and ongoing private development introducing additional impervious surfaces that may increase runoff.

The Fort Missoula Regional Park is a large-scale new park being constructed on the south side of South Avenue, approximately 1.5 miles east of the proposed project. The two-phase construction of the park is nearly complete, and includes new sport fields, park amenities, and open space areas constructed on a former vacant gravel pit. Effects from the regional park are not anticipated to negatively impact habitat or water quality.

No additional future federal, state, local, or private actions of regional significance that are reasonably certain to occur have been identified within the vicinity of the proposed project. Future projects occurring on or adjacent to the Bitterroot River, the nearby Clark Fork River, or their tributaries also designated as bull trout critical habitat could result in additional temporary impacts on bull trout and its critical habitat. No long-term cumulative impacts are anticipated.

4 References

- Bjornn, T.C., and D.W. Reiser. 1991. Habitat Requirements of Salmonids in Streams. From W.R. Meehan, ed. Influences of Forest and Rangeland Management on Salmonid Fishes and Their Habitats. American Fisheries Society Special Publication. 19:83-138.
- Brenkman, S.J., and S.C. Corbett. 2005. Extent of anadromy in bull trout and implications for conservation of a threatened species. *North American Journal of Fisheries Management* 25:1073-1081.
- Cavender, T.M. 1978. Taxonomy and distribution of the bull trout, *Salvelinus confluentus* (Suckley), from the American Northwest. *California Fish and Game* 64:139-174.
- DEQ (Montana Department of Environmental Quality). 2016. Clean Water Act Information Center (CWAIC). Accessed at < <http://svc.mt.gov/deq/dst/#/app/cwaic>>. Accessed on June 23, 2016.
- Downs, C.C., D. Horan, E. Morgan-Harris, and R. Jakubowski. 2006. Spawning demographics and juvenile dispersal of an adfluvial bull trout population in Trestle Creek, Idaho. *North American Journal of Fisheries Management* 26:190-200.
- Fraley, J.J., and B.B. Shepard. 1989. Life history, ecology, and subpopulation status of migratory bull trout (*Salvelinus confluentus*) in the Flathead Lake and River system, Montana. *Northwest Science* 63:133-143.
- FWP (Montana Fish, Wildlife and Parks). 2016. Montana Fisheries Information System (MFISH). Fish Distribution Data for Bitterroot River. Accessed at <<http://fwp.mt.gov/fishing/mFish/newSearch.html>>. Accessed on May 16, 2016.
- FWP. 2015. Personal communication between Ladd Knotek (FWP) and Becky Holloway (HDR). July 23, 2015.
- Halterman, M., M.J. Johnson, J.A. Holmes and S.A. Laymon. 2015. A Natural History Summary and Survey Protocol for the Western Distinct Population Segment of the Yellow-billed Cuckoo: U.S. Fish and Wildlife Techniques and Methods, 45 p.
- Hastings, M. C. and A. N. Popper, 2005. Effects of Sound on Fish, prepared by Jones & Stokes, Sacramento, CA, for California Department of Transportation, Sacramento, CA.
- Hughes, J. M. 2015. Yellow-billed Cuckoo (*Coccyzus americanus*), version 2.0. In *The Birds of North America* (P. G. Rodewald, Editor). Cornell Lab of Ornithology, Ithaca, NY, USA. <https://doi.org/10.2173/bna.418>.
- Knotek, L. 2005. Middle Clark Fork River and Missoula Area 2004 Fisheries Status Report. Montana Fish, Wildlife & Parks. Missoula, Montana.
- Laughlin, J. 2005. Underwater Sound Levels Associated With Pile Driving on the SR 24, I-82 to Keys Road Project – Yakima River. Washington State Department of Transportation Office of Air Quality and Noise, Seattle, WA.
- McPhail, J.D., and J.S. Baxter. 1996. A review of bull trout (*Salvelinus confluentus*) life-history and habitat use in relation to compensation and improvement opportunities. Department of Zoology, University of British Columbia, Vancouver, British Columbia. Fisheries Management Report No. 104.

- Missoula County Community & Planning Services. 2016. Missoula County Parks, Trails, & Open Lands Program interactive web map. Accessed at <<http://gis.missoulacounty.us/CAPS/ParksAndTrails/>>. Accessed on July 13, 2016.
- MTNHP (Montana Natural Heritage Program). 2016a. Montana Point Observations Export for Sections 26, 27, 34, 35, Township 13 N, Range 20 W. Accessed at <<http://mtnhp.org/mapviewer/?t=1>>. Accessed May 4, 2016.
- MTNHP. 2018. Yellow-billed Cuckoo (*Coccyzus americanus*). Montana Natural Heritage Program and Montana Fish, Wildlife and Parks. Available online: <<http://FieldGuide.mt.gov/speciesDetail.aspx?elcode=ABNRB02020>>. Accessed August 17, 2018.
- MSL (Montana State Library). 2016. Montana Cadastral Mapping Project. Accessed at <<http://svc.mt.gov/msl/mtcadastral/>>. Accessed on July 13, 2016.
- NOAA (National Oceanic and Atmospheric Administration). 2016. NOAA Fisheries. Endangered and Threatened Marine Species under NMFS' Jurisdiction. Accessed at <<http://www.nmfs.noaa.gov/pr/species/esa/listed.htm>>. Accessed on October 6, 2016.
- Popper, A. N., 2003. "Effects of Anthropogenic Sounds of Fishes," Fisheries, Vol. 28, No. 10, pp. 24–31.
- Reid, S.M., S. Stoklosar, S. Metikosh, J. Evans, and T. Huffman 2002. Effects of Natural Gas Pipeline Water Crossing Replacement on the Benthic Invertebrate and Fish Communities of Big Darby Creek, Ohio. In Environmental Concerns in Rights-of-Way Management. Seventh International Symposium. J.W. Goodrich-Mahoney, D.F. Mutrie, and C.A. Build (eds.). Elsevier Science, Ltd. cited in 2.2 & 3.2
- Rieman, B.E., and J.D. McIntyre. 1993. Demographic and habitat requirements for conservation of bull trout. General Technical Report INT-302. U.S. Department of Agriculture, Forest Service, Intermountain Research Station, Ogden, Utah.
- StreamNet GIS Data. 2016. Metadata for Pacific Northwest salmonid and critical habitat distribution. Portland (OR) : <http://www.streamnet.org/online-data/GISData.html> (Accessed August 2016).
- Turnpenny, A., K. P. Thatcher, R. Wood, and J. Nedwell, 1994. The Effects on Fish and Other Marine Animals of High-Level Underwater Sound, Report FRR 127/94, prepared by Fawley Aquatic Research Laboratory, Ltd., Marine and Freshwater Biology Unit, Southampton, United Kingdom.
- USDA NRCS (U.S. Department of Agriculture Natural Resources Conservation Service). 2016a. Major Land Resource Regions Custom Report for Missoula County, Montana. March 3, 2016.
- USFWS (U.S. Fish and Wildlife Service). 2018a. Montana Ecological Field Office Endangered, Threatened, Proposed and Candidate Species by Montana County. Published July 16, 2018. <http://www.fws.gov/montanafieldoffice/Endangered_Species/Listed_Species/countylist.pdf> . Accessed on August 15, 2018.
- USFWS. 2018b. Environmental Conservation Online System (ECOS): Yellow-billed cuckoo (*Coccyzus americanus*). Species Profile. Available online:

<<https://ecos.fws.gov/ecp0/profile/speciesProfile?sPCODE=B06R>>. Accessed September 10, 2018.

- USFWS. 2015a. Personal email communication between Mike McGrath, USFWS, and Becky Holloway, HDR. August 12, 2015.
- USFWS. 2015b. Recovery plan for the coterminous United States population of bull trout (*Salvelinus confluentus*). Portland, Oregon. xii + 179 pages.
- USFWS. 2015c. Draft Columbia Headwaters Recovery Unit Implementation Plan for Bull Trout Recovery 26 Plan.
- USFWS. 2010a. Endangered and Threatened Wildlife and Plants; Revised Designation of Critical Habitat for Bull Trout in the Coterminous United States, Final Rule. FR Vol. 75, No.200: 63898- 64069.
- USFWS. 1998a. Determination of Threatened Status for the Klamath River and Columbia River Distinct Population Segments of Bull Trout. Federal Register 63(111):31647.
- USFWS. 1998b. Endangered Species Consultation Handbook. Procedures For Conducting Consultation and Conference Activities Under Section 7 of the Endangered Species Act. March 1998.
- USGS (U.S. Geological Survey). 2014. USGS National Hydrography Database (NHD) Montana Spatial Data Infrastructure (MSDI) geospatial data. Montana Natural Resource information System. Montana State Library. Downloaded September 2014.
- WSDOT (Washington State Department of Transportation). 2015. Biological Assessment Preparation for Transportation Projects - Advanced Training Manual. Version 2015
- Woods, Alan J., Omernik, James, M., Nesser, John A., Shelden, J., Comstock, J.A., Azevedo, Sandra H., 2002, Ecoregions of Montana, 2nd edition (color poster with map, descriptive text, summary tables, and photographs). Map scale 1:1,500,000.

APPENDIX A: Yellow-billed Cuckoo Survey Report



Yellow-billed Cuckoo Survey Report

June-July 2018

South Avenue Bridge Project

Bitterroot River - W of Missoula

BR 9032(65)

UPN 6296000

Missoula County, Montana

Prepared for:



Missoula County Department of Public Works

6086 Training Drive

Missoula, MT 59808

Prepared by:



700 SW Higgins Avenue, Ste. 200

Missoula, MT 59803

September 2018

Abbreviations and Acronyms

°F	degrees Fahrenheit
FHWA	Federal Highway Administration
MDT	Montana Department of Transportation
NRCS	Natural Resources Conservation Service
Project	South Avenue Bridge Project
ROW	Right-of-way
USDA	U.S. Department of Agriculture
USFWS	U.S. Fish and Wildlife Service
YBCU	Yellow-billed cuckoo

Table of Contents

1	Introduction.....	1
2	Project Description	1
3	Environmental Conditions	3
4	Species Description	3
5	Methods.....	4
6	Results and Discussion	6
	6.1 YBCU Suitable Habitat (Survey Sites).....	6
	6.2 Incidental Wildlife	7
	6.3 Yellow-billed Cuckoo Detections.....	9
7	Conclusion.....	9
8	References	10

Appendices

Appendix A: Photographs

Appendix B: Figures

Figures

Figure 1: Project Areas	2
Figure 2: Study Area and Survey Sites Overview.....	5

Tables

Table 1: Survey Schedule	4
Table 2: Wildlife Detected	7

1 Introduction

HDR was contracted to conduct protocol presence/absence surveys for federally threatened western yellow-billed cuckoo (YBCU) (*Coccyzus americanus occidentalis*) for the South Avenue Bridge Project (project) in Missoula County, Montana. The project will generally involve the construction of a new two-lane bridge to replace the existing one-lane bridge *Maclay Bridge*. The purpose of the project is to enhance the operational characteristics, increase safety and improve physical conditions for the public by constructing a new river crossing that meets current design standards as well as future growth in traffic volume.

HDR biologist Andrew Phillips (U.S. Fish and Wildlife Service [USFWS] Native Endangered and Threatened Species Recovery Permit TE64613B-2) conducted the surveys following the protocol established by the USFWS for YBCU (Halterman et al 2015). As requested by the USFWS field office, surveys were conducted within a *one-mile radius surrounding the proposed project area* (study area). The large study area was requested because USFWS staff suggested that construction-related noise could potentially disturb YBCU up to one mile from the project area. Survey results will be utilized for analysis and inclusion in the Biological Assessment in support of an effects evaluation as required by Section 7 of the Endangered Species Act.

2 Project Description

Missoula County, in cooperation with the Montana Department of Transportation (MDT) and Federal Highway Administration (FHWA), is proposing to construct a new bridge across the Bitterroot River at the western terminus of South Avenue to connect with River Pines Road immediately west of the river. The project is located in Missoula County, outside of Missoula city limits. The project is located in Sections 26, 27, 34 and 35 of Township 13 North, Range 20 West, Montana Principle Meridian. The proposed South Avenue Bridge would involve construction of a new two-way (two-lane) bridge with bicycle/pedestrian accommodations separated from vehicular traffic. The proposed bridge design is four-span welded plate girder and approximately 746 feet long. The project limits extend between the intersection of South Avenue and Hanson Drive to the east and the intersection of River Pines Road and Blue Heron Lane to the west. A segment of River Pines Road would be realigned to include a T-intersection on the west side of the river. The project includes removal of the existing single-lane Maclay Bridge on North Avenue located approximately 0.4 mile downstream of the proposed bridge location. The conceptual alignment centerline and associated project areas are shown in **Figure 1**.

Construction of the project is anticipated to occur over two seasons, with construction of the new bridge occurring in year one and removal of the Maclay Bridge during the second year. Construction would be scheduled to occur during the summer (July 1 through September 30). The methods for constructing the new bridge and removing Maclay Bridge have not yet been determined and would depend largely on the approach proposed by the selected construction contractor. It is likely that construction would include temporary work structures such as cofferdams, diversion blocks, work trestles, or other means to access and work within, or over, the Bitterroot River. To the extent possible, construction staging for the project will occur within the existing right-of-way (ROW) and previously disturbed areas.

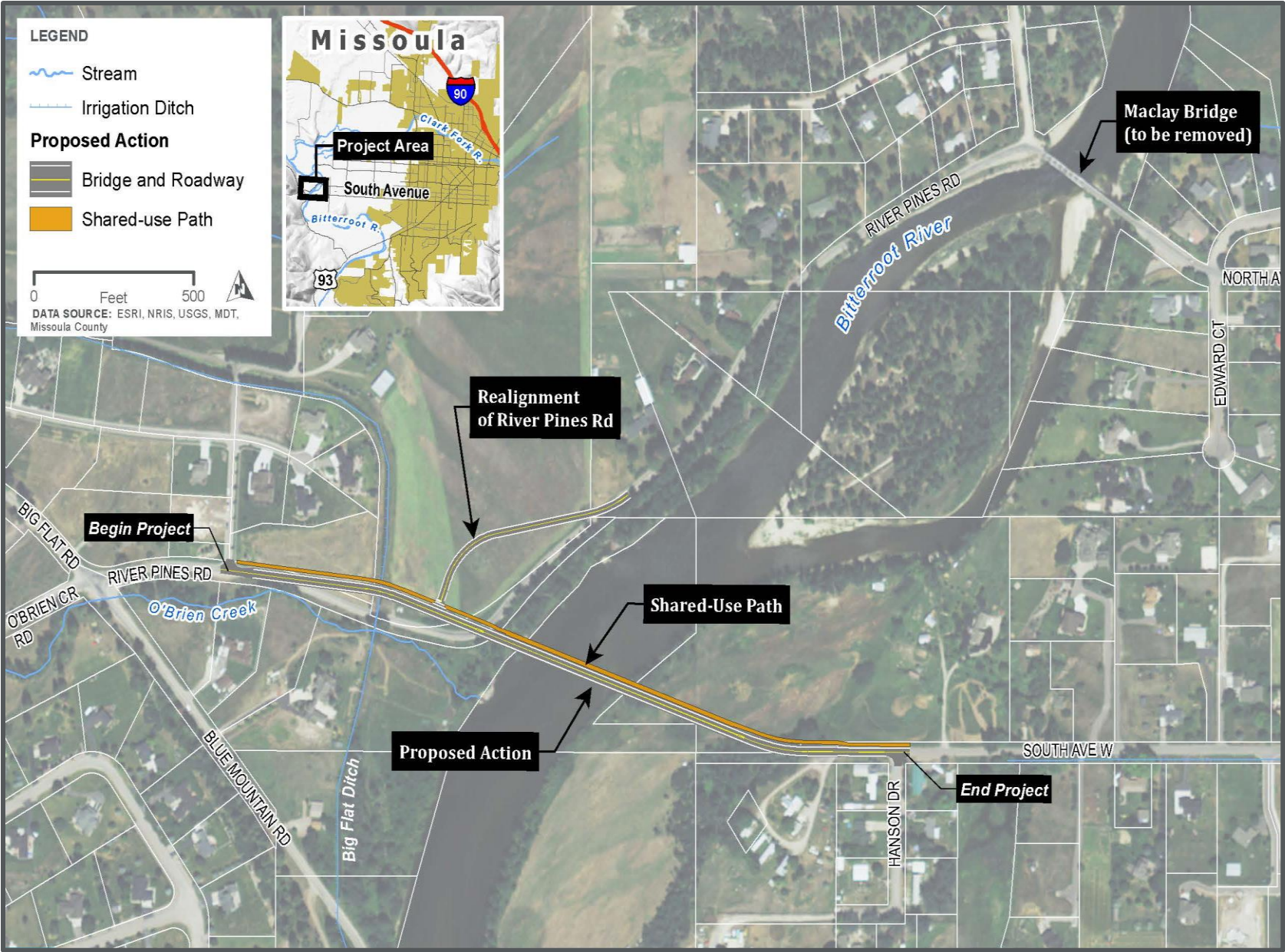

Figure 1: Project Areas

3 Environmental Conditions

The project is located within the Bitterroot River floodplain. This site is within the Middle Rockies level 3 ecoregion and the Bitterroot-Frenchtown Valley level 4 ecoregion (Woods et al. 2002, USEPA 2012). According to Woods et al. (2002) and U.S. Department of Agriculture (USDA) Natural Resources Conservation Service (NRCS) (2016), the Bitterroot-Frenchtown Valley is an intermontane valley with floodplains, terraces, hills, and fans, with thick alluvial, colluvial, outwash, and till soils formed from the end moraines of alpine glaciers. Climate in the Bitterroot-Frenchtown Valley is characterized by precipitation that averages 12 to 24 inches per year. Wintertime temperatures typically fall below freezing, while summertime temperatures peak in the high 80's, resulting in snowmelt runoff and high stream flows in the spring.

In the vicinity of the project, the Bitterroot River floodplain has moderate development. Residential and agricultural land uses abut the Bitterroot River in the study area, which have resulted in the fragmentation of the historically contiguous riparian woodlands. The remaining blocks of hardwood and coniferous riparian woodlands within the area are relatively small and non-contiguous in most areas along the Bitterroot River. The largest stands of riparian woodlands occur on Kelly Island, where no agriculture or development has occurred.

4 Species Description

Historically, the western population of YBCU have nested west of the Continental Divide from British Columbia down to northern Mexico and wintered in South America. The USFWS identifies YBCUs west of the Continental Divide as a Distinct Population Segment (DPS) for conservation purposes and this DPS has been listed as threatened under the ESA since 2014 (79 FR 59991 60038).

The YBCU is a medium sized bird that is greyish-brown above and pale below. The species' long tail with distinct black-and-white patches, and a long, curved, and mostly yellow bill. The primary food for the YBCU are caterpillars and katydids, but also includes other large insects, small lizards, frogs, bird eggs, and some fruits (MTNHP 2018). Throughout their western range, preferred breeding habitat includes open woodland (especially where undergrowth is thick), parks, and deciduous riparian woodland. Today, nesting is primarily restricted to sites in Arizona, California, and New Mexico (MTNHP 2018).

Suitable habitat in Montana is composed of stands of cottonwoods (*Populus* spp.) mixed with a dense willow understory (*Salix* spp.). YBCUs nests in low to moderate-elevation, riparian woodlands, mostly comprised of native broadleaf trees and shrubs (MTNHP 2018). As summarized by Halterman et al. (2015), nesting has not been documented in small, isolated riparian patches of two acres or less, or within linear patches less than 30 feet in width. However, such patches of habitat may be used for stop-over foraging during migration. The western subspecies of YBCU requires at least 20 hectares (50 acres) of suitable riparian woodlands for nesting, and often chooses to nest in areas with 80 hectares or more of suitable woodlands (Halterman et al. 2015; MTNHP 2018).

No proposed critical habitat for the YBCU occurs within the study area or anywhere in the state of Montana.

5 Methods

Using information and survey guidance obtained from the USFWS survey protocol (Halterman et al. 2015), HDR conducted protocol presence/absence surveys for the YBCU between June 16 and July 30 of 2018. Four surveys spanning three survey periods were conducted as required by protocol (**Table 1**). Surveys were only conducted within suitable habitat for the YBCU (survey sites) (**Figure 2**). Each survey site was visited a minimum of four times within the breeding season, with 12 to 15 days between surveys at each site (Halterman et al. 2015). The four collective surveys ensure an 80 percent probability of detecting individual YBCUs and a 95 percent probability of detecting YBCUs during the nesting season (Halterman et al. 2015). Due to differences in breeding seasons across the western United States, a survey window of plus or minus three days is acceptable for the start and end of each survey period (Halterman et al. 2015).

Table 1: Survey Schedule

Survey #	Survey Dates (2018)	Protocol Survey Period	
		Period #	Date Range (± 3 days)
1	June 17 – June 18	1	(Jun 15 – Jul 1)
2	June 30 – July 1	2	(Jul 1 – Jul 31)
3	July 14 – July 15		
4	July 29 – July 30	3	(Jul 31 – Aug 15)

HDR followed protocol guidance which generally involved (1) the pre-survey identification of suitable habitat within the study area and (2) subsequent use of a call-playback technique to elicit responses from YBCU within identified suitable habitat. Due to low unsolicited calling rates of YBCU, the call-playback survey technique helps to achieve a high degree of confidence regarding the species' presence or absence within the study area. A pre-survey desktop review of aerial imagery was conducted to identify habitat within the study area, enabling a focused and efficient survey. Based upon this pre-survey analysis, two distinct areas were identified for survey. The two survey sites include habitat along the banks of the Bitterroot River and within Kelly Island. One survey transect within each survey site was selected prior to the first site visit, and was modified as needed based upon an on-site evaluation of habitat extent and suitability. Suitable habitat was surveyed along each transect using a combination of river (inflatable kayak) and foot-access. Due to the use of the Bitterroot River for access to habitat during the survey, transects were surveyed in the same pattern for all four surveys.

Each complete survey required two days to cover all suitable habitat within the study area. Per the USFWS protocol, the surveyor listened for unsolicited YBCU vocalizations for approximately one minute before playing the YBCU “kowlp” contact call using a FoxPro Game caller. The contact call was then broadcast five times on one minute intervals at each survey point. Survey points were spaced at approximately 100 meter apart along the survey transects. The surveys were started as soon as there was enough light to safely navigate and continued until 1100 hours, depending on temperature, wind, and rain. Temperature and other weather data were recorded using a Kestrel 3000 Pocket Weather Meter.

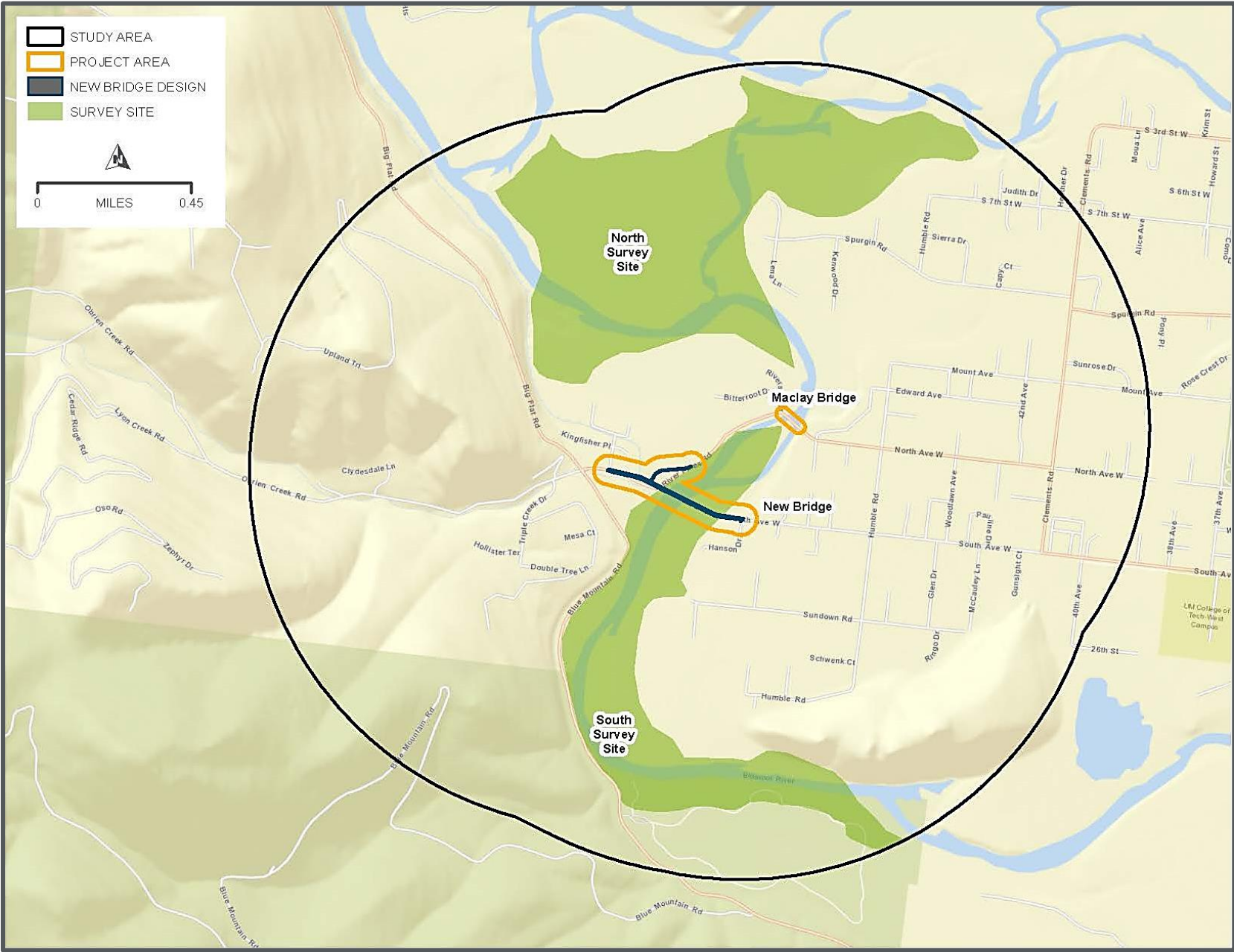

Figure 2: Study Area and Survey Sites Overview

6 Results and Discussion

Two distinct sites were identified as containing potentially suitable habitat (**Appendix B [Figures A and B]**). The two sites are located: (1) along the Bitterroot River in the southern half of the study area (*south survey site*), and (2) on Kelly Island and adjacent peninsular landforms in the northern half of the study area (*north survey site*).

6.1 YBCU Suitable Habitat (Survey Sites)

The two survey sites in the study area have similar vegetation characteristics composed of potentially suitable riparian habitat for YBCU. The two survey sites are composed of native vegetation dominated by a black cottonwood (*Populus balsamifera*) overstory and an herbaceous understory, with an occasional shrubby willow (*Salix* spp.) understory (**Appendix A: Photos 1 through 9**). Where present, the shrub understory is composed of sandbar willow (*Salix exigua*), red osier dogwood (*Cornus sericea*), Wood's rose (*Rosa woodsii*), and common snowberry (*Symphoricarpos albus*). Herbaceous vegetation is dominated by brome (*Bromus* spp.), Canada thistle (*Cirsium arvense*), goldenrod (*Solidago* sp.), and common tansy (*Tanacetum vulgare*).

The habitat within the two survey sites is composed of patches of riparian vegetation (two hectares or greater) along the banks of the Bitterroot River and on Kelly Island (**Appendix B: Figures A and B**). Much of the habitat is naturally bisected by the Bitterroot River or its floodplain channels, with some areas (particularly within the south survey site) having been cleared for agriculture. The 2018 summer experienced high runoff flows due to significant snowpack accumulation over winter. The high runoff resulted in flooding and inundation of most floodplain channels in the study area. Insect populations responded to the higher water availability, particularly mosquitos which were common throughout the study area during the first two surveys. Grasshopper populations were common during the last two surveys and moths were occasionally noted throughout the study area. Tadpoles were common in ponded areas.

The patches of riparian woodlands within the two survey sites contain about 40 percent or more canopy cover. These woodlands are dominated by black cottonwood with about 50 percent cover on average, but lack a shrub understory in most areas (**Appendix A: Photos 1, 3 and 4**). The presence of a shrub understory is correlated with a higher percentage of overstory canopy closure. That is, areas with higher canopy closure (over about 70 percent) contained at least some shrub understory. However, areas with a canopy closure below 60 percent contained little to no shrub understory. Based upon this pattern, less than 10 percent of habitat within the study area contain both a dense shrub and canopy layer typical of suitable YBCU nesting habitat.

The **south survey site** (about 80 hectares total) is part of approximately two-linear-miles of riparian habitat within the floodplain of the Bitterroot River. Of the 80 hectare survey site, about 40 hectares contain patches of suitable habitat. These patches extend no further than about 200 meters from the ordinary high water mark of the Bitterroot River. Typical riparian woodlands within this site are characterized by a black cottonwood overstory averaging about 50 percent canopy cover (**Appendix A: Photos 1 and 3**). Where present, the understory is dominated by a patchy composition of sandbar willow and other sub-dominant shrubs averaging less than 10 percent of the entire south survey site. The area with the densest vegetation and other characteristics

required for YBCU nesting is within a linear strip of habitat between Blue Mountain Road and the western bank of the Bitterroot River. At about 6 hectares, this strip of habitat contains both a dense overstory of cottonwood and a dense shrub understory (**Appendix A: Photo 8**).

The **north survey site** (about 150 hectares total) has a similar vegetation composition to the south site. Most of the northern site’s riparian woodlands have a cottonwood overstory averaging about 50 percent cover. These woodlands are fragmented by large grassland meadows and wide floodplain channels (**Appendix A: Photos 5 through 7**). Within the riparian woodlands, small and isolated patches (less than 5 hectares each) occur that contain both a dense overstory and shrub understory similar to that used by YBCU for nesting. However, the collective areas of suitable nesting habitat amount to less than 10 percent (about 12 hectares) of the total survey site habitat.

6.2 Incidental Wildlife

Wildlife incidentally observed during the 2018 survey were detected by audible vocalizations or visually (**Table 2**). During the survey, 49 species of birds were detected incidentally. Of these species, six were detected nesting at least once: spotted sandpiper (*Actitis macularius*), Lewis’s woodpecker (*Melanerpes lewis*), hairy woodpecker (*Dryobates villosus*), downy woodpecker (*Dryobates pubescens*), northern flicker (*Colaptes auratus*), and osprey (*Pandion haliaetus*). Active osprey and Lewis’s woodpecker nests were detected within 200 meters of the Maclay Bridge (**Appendix A: Photo 10**). Other wildlife observed during the survey included trout (unknown species), tadpole amphibians in most ponded areas, and a significant insect population, particularly during the first two surveys.

Table 2: Wildlife Detected

Common Name	Scientific Name
Birds	
American crow	<i>Corvus brachyrhynchos</i>
American kestrel	<i>Falco sparverius</i>
American robin	<i>Turdus migratorius</i>
American wigeon	<i>Mareca americana</i>
Bald eagle	<i>Haliaeetus leucocephalus</i>
Belted kingfisher	<i>Megaceryle alcyon</i>
Black-capped chickadee	<i>Poecile atricapillus</i>
Black-chinned hummingbird	<i>Archilochus alexandri</i>
Black-headed grosbeak	<i>Pheucticus melanocephalus</i>
Blue grosbeak	<i>Passerina caerulea</i>
Brewer’s blackbird	<i>Euphagus cyanocephalus</i>
Brown-headed cowbird	<i>Molothrus ater</i>
Cedar waxwing	<i>Bombycilla cedrorum</i>
Cliff swallow	<i>Petrochelidon pyrrhonota</i>
Collared dove	<i>Streptopelia decaocto</i>
Common merganser	<i>Mergus merganser</i>

Table 2: Wildlife Detected

Common Name	Scientific Name
Birds	
Common raven	<i>Corvus corax</i>
Cooper's hawk	<i>Accipiter cooperii</i>
Downy woodpecker	<i>Dryobates pubescens</i>
Eastern kingbird	<i>Tyrannus tyrannus</i>
Golden eagle	<i>Aquila chrysaetos</i>
Gray catbird	<i>Dumetella carolinensis</i>
Great blue heron	<i>Ardea herodias</i>
Great horned owl	<i>Bubo virginianus</i>
Hairy woodpecker	<i>Dryobates villosus</i>
House finch	<i>Haemorhous mexicanus</i>
Killdeer	<i>Charadrius vociferus</i>
Lazuli bunting	<i>Passerina amoena</i>
Lewis's woodpecker	<i>Melanerpes lewis</i>
Mallard	<i>Anas platyrhynchos</i>
Mourning dove	<i>Zenaida macroura</i>
Northern flicker	<i>Colaptes auratus</i>
Northern rough-winged swallow	<i>Stelgidopteryx serripennis</i>
Olive-sided flycatcher	<i>Contopus cooperi</i>
Osprey	<i>Pandion haliaetus</i>
Pileated woodpecker	<i>Dryocopus pileatus</i>
Pine siskin	<i>Spinus pinus</i>
Red-breasted nuthatch	<i>Sitta canadensis</i>
Red-tailed hawk	<i>Buteo jamaicensis</i>
Song sparrow	<i>Melospiza melodia</i>
Spotted sandpiper	<i>Actitis macularius</i>
Tree swallow	<i>Tachycineta bicolor</i>
Violet-green swallow	<i>Tachycineta thalassina</i>
Western wood pewee	<i>Contopus sordidulus</i>
White-breasted nuthatch	<i>Sitta carolinensis</i>
Willow flycatcher	<i>Empidonax traillii</i>
Wood duck	<i>Aix sponsa</i>
Yellow warbler	<i>Setophaga petechia</i>
Yellow-rumped warbler	<i>Setophaga coronata</i>
Mammals	
coyote	<i>Canis latrans</i>
River otter	<i>Lontra canadensis</i>
White-tailed deer	<i>Odocoileus virginianus</i>

6.3 Yellow-billed Cuckoo Detections

No YBCU were detected during any of the four surveys.

Environmental conditions during all surveys were within protocol parameters. Weather conditions ranged from the low 50°F to almost 80°F during all surveys. There was some intermittent cloud cover during most surveys and light, intermittent rain during both mornings of the first survey. Average wind speed ranged from zero to six miles-per-hour for all surveys. Background noise levels were similar during all surveys, fluctuating between 55 and 60 decibels and rarely exceeded 65 decibels during vehicle and airplane traffic.

7 Conclusion

The loss and degradation of native riparian habitat throughout the YBCU range in the west have played a major role in the bird's decline. Much of the riparian habitat in the west that is preferred by the YBCU for nesting has been converted to agricultural uses or otherwise disturbed by development or flood control projects. Habitat loss is considered the leading factor contributing to population declines of the YBCU throughout the western DPS. This pattern of habitat loss and degradation was observed within the study area, primarily from agriculture and housing land development. Regardless of habitat loss, the YBCU is a rare visitor to Montana, with only eight sightings having been reported in western Montana since 1959 (USFWS 2015). Of the few recorded detections of YBCU in Montana, no behavioral evidence exists that suggests breeding has occurred in the state (MTNHP 2018). Therefore, the YBCU is considered a transient migrant in western Montana by the USFWS (USFWS 2015).

The study area and surrounding Missoula valley has riparian woodlands with some components of YBCU suitable habitat. Four presence/absence surveys for YBCU were conducted in potential habitat within the study area. The study area was found to contain patches of relatively small and homogenous riparian woodlands of limited complexity in most areas. Those woodlands could be used by YBCU when foraging and migrating, but they do not have the multi-storied complexity that is known to attract YBCU nesting. The high seasonal runoff in the area contributed to some increased insect populations, primarily mosquitos and grasshoppers. However, caterpillars (YBCU primary food) were not detected within the study area and likely occurred in low numbers.

The survey was conducted within a year offering a higher potential for YBCU occurrence and detection, due primarily to the increased food availability (mostly grasshoppers and amphibians) resulting from the higher seasonal runoff. However, due to the rare historical occurrence of YBCU in Montana combined with the lack of survey detections and marginal habitat, the species is unlikely to occur in the study area. If the species does occur, the individual(s) are unlikely to use the study area other than for foraging during transient movement to higher quality habitat or during migration.

8 References

- USDA NRCS 2016 USDA NRCS (U.S. Department of Agriculture Natural Resources Conservation Service). 2016a. Major Land Resource Regions Custom Report for Missoula County, Montana. March 3, 2016.
- USEPA 2012 USEPA (US Environmental Protection Agency). 2012. Level IV Ecoregions of Montana GIS shapefile. Published 2012. Available online: <http://archive.epa.gov/wed/ecoregions/web/html/mt_eco.html>. Accessed August 17, 2018.
- Woods et al., 2002 Woods, Alan J., Omernik, James, M., Nesser, John A., Sheldon, J., Comstock, J.A., Azevedo, Sandra H., 2002, Ecoregions of Montana, 2nd edition (color poster with map, descriptive text, summary tables, and photographs). Map scale 1:1,500,000.
- Halterman et al. 2015 Halterman, M.D., M.J. Johnson, J.A. Holmes and S.A. Laymon. 2015. A Natural History Summary and Survey Protocol for the Western Distinct Population Segment of the Yellow-billed Cuckoo: U.S. Fish and Wildlife Techniques and Methods, 45 p.
- Hughes 2015 Hughes, J. M. 2015. Yellow-billed Cuckoo (*Coccyzus americanus*), version 2.0. In The Birds of North America (P. G. Rodewald, Editor). Cornell Lab of Ornithology, Ithaca, NY, USA. <https://doi.org/10.2173/bna.418>.
- MTNHP 2018 MTNHP (Montana Natural Heritage Program). 2018. Yellow-billed Cuckoo (*Coccyzus americanus*). Montana Natural Heritage Program and Montana Fish, Wildlife and Parks. Available online: <<http://FieldGuide.mt.gov/speciesDetail.aspx?elcode=ABNRB02020>>. Accessed August 17, 2018.
- USFWS 2015 USFWS. 2015. Personal email communication between Mike McGrath, USFWS, and Becky Holloway, HDR. August 12, 2015.



Appendix A:
Photographs



Photo 1 – Vegetation in the south survey site along Maclay Flat Nature Trail



Photo 2 – Habitat along the Bitterroot River just north of the Maclay Bridge



Photo 3 – South survey site area with no shrub understory and patchy herbaceous layer



Photo 4 – Area on Kelly island with only herbaceous understory



Photo 5 – Floodplain channel on Kelly Island with limited shrub understory



Photo 6 – Wide floodplain channel on Kelly Island with pockets of willow vegetation



Photo 7 – Large herbaceous meadow fragmenting the forested riparian habitat on Kelly Island



Photo 8 – Patch of habitat along Bitterroot River with a dense shrub and canopy cover



Photo 9 – Habitat patch on Kelly Island (representative of the densest habitat in study area)



Photo 10 – Osprey with fish near its active nest adjacent to the existing Maclay Bridge



Appendix B:
Figures

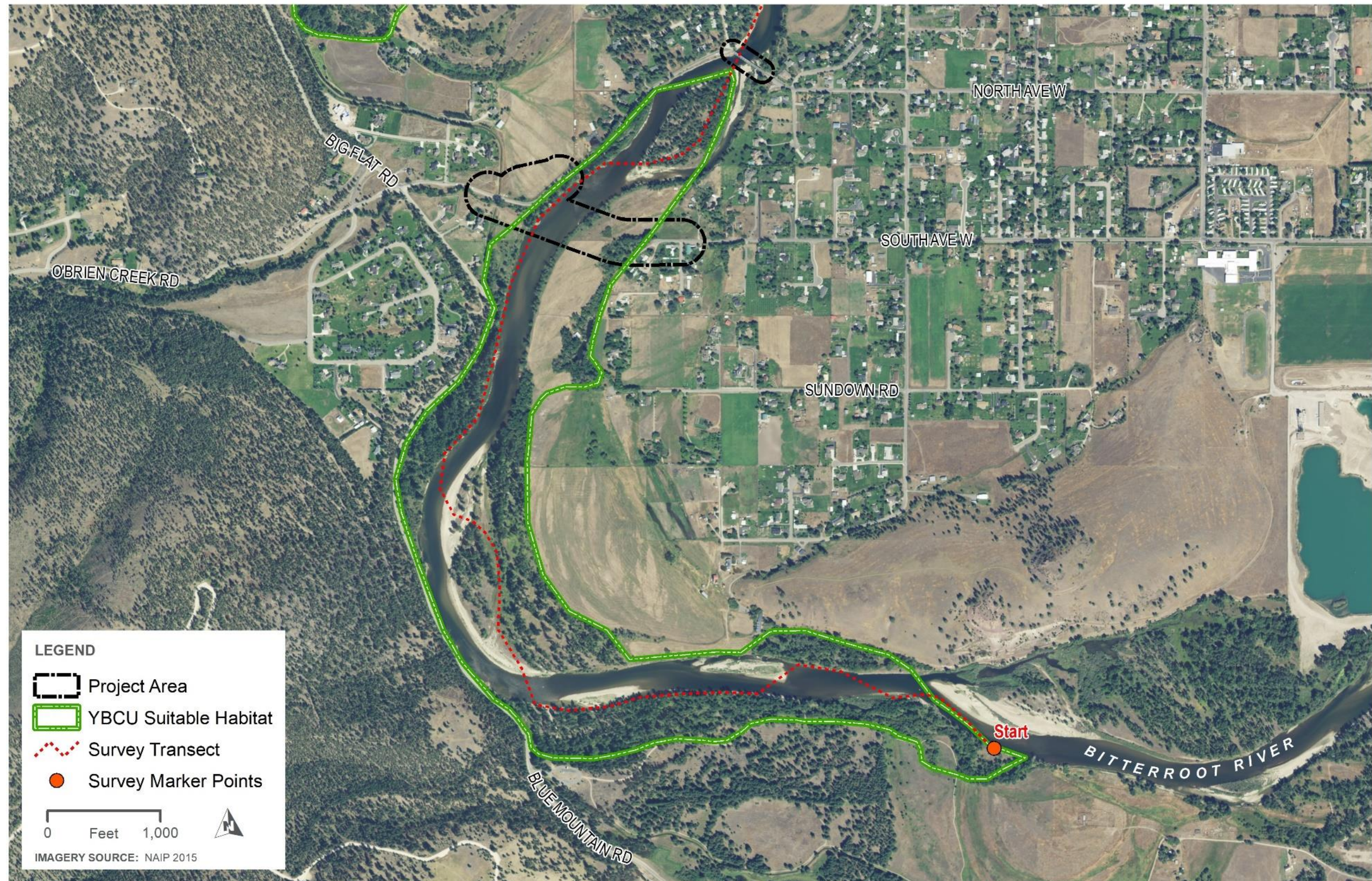

Figure A: South Survey Site

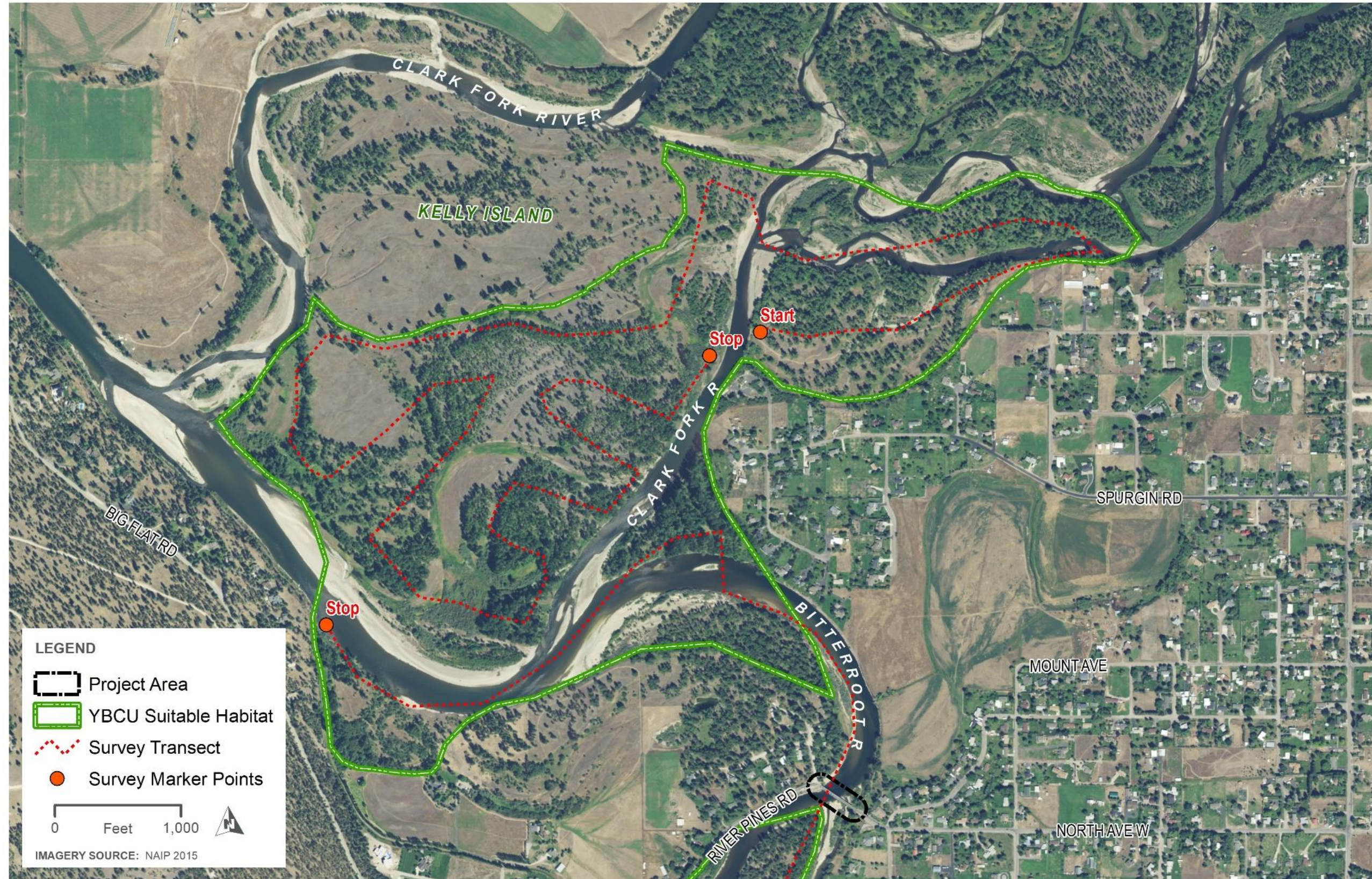

Figure B: North Survey Site

APPENDIX B: Representative Site Photos



Photo 1. West terminus of South Avenue, looking west at stand of deciduous trees along proposed bridge alignment



Photo 2. Right (east) bank of Bitterroot River, looking upstream



Photo 3. Wetland 1 on right bank of Bitterroot River



Photo 4. Approximate location of proposed bridge alignment across the Bitterroot River, looking west at left bank



Photo 5. West bank of Bitterroot River in vicinity of proposed bridge alignment, looking downstream



Photo 6. Wetland 2 on left bank of Bitterroot River, looking downstream



Photo 7. Confluence of O'Brien Creek and Bitterroot River looking upstream on left bank of Bitterroot River.

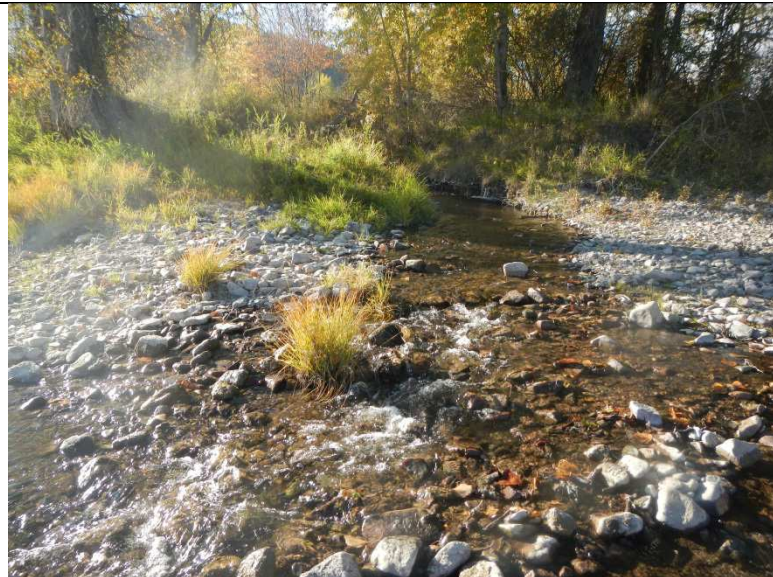

Photo 8. O'Brien Creek, looking upstream at confluence with Bitterroot River.

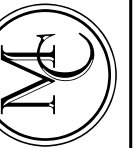

Photo 9. Maclay Bridge, looking at right bank abutments



Photo 10. Maclay Bridge, looking across Bitterroot River at left bank.

APPENDIX C: Preliminary Bridge Layout Plan
Preliminary Maclay Bridge Removal Plan



REVISED	REVISED	REVISED	CHECKED	DRAWN	DESIGNED
			XX-XX-XX	2-28-17	2-27-17
			X.X.X.	G.H.S.	B.K.C.

UPN NUMBER 6296000
 BRIDGE ID XXXXXXXXXXXXXXXX
 DRAWING NO.

NOTES

FINISHED GRADE: Finished grade of bridge at centerline roadway is the same as the Profile Grade shown on Road Plans.

LIVE LOAD: Standard HL-93 loading.

SPECIFICATIONS: Montana Department of Transportation and the Montana Transportation Commission Standard Specifications for Road and Bridge Construction, 2014 edition, and any amendments thereto, and the Special Provisions govern unless otherwise noted. The design was prepared in accordance with AASHTO LRFD Bridge Design Specifications, Seventh edition - 2014 with 2015 and 2016 Interim revisions.

REINFORCING STEEL: Use new deformed type reinforcing steel meeting the requirements of AASHTO M 31 Grade 60 or ASTM Specification A 706 Grade 60 as specified. Include all costs associated with furnishing and placing new reinforcing steel in the unit price bid for either Reinforcing Steel, Reinforcing Steel - Epoxy or Reinforcing Steel - Seismic.

CAST IN PLACE CONCRETE: Except as noted on Sheet No. Bx, use Concrete Class Structure for all substructure concrete and Concrete Class Deck for all superstructure and barrier concrete.

CONCRETE STRENGTH: Use $f_c = 4000$ p.s.i. for Concrete Class Structure. Use $f_c = 4000$ p.s.i. for Concrete Class Deck.

STRUCTURE EXCAVATION: Include structure excavation in the unit price bid for Concrete Class Structure at Bents. Structure Excavation at Piers will be calculated from natural groundlines as they exist prior to construction.

STRUCTURAL STEEL: All structural steel will be measured and paid for on the lump sum basis as set forth in the Standard Specifications. Use structural steel meeting the requirements of AASHTO M 270 Grade 50W; Estimated weight = XXX,XXX lbs.

SEAL DEPTH: Seal depth has been sized to resist hydrostatic uplift forces produced by a water surface elevation of XXXX.XX. If higher elevations are encountered, consult the Project Manager for any modifications required to the seal.

TRAFFIC CONTROL PLAN AND SEQUENCE OF OPERATIONS: See Special Provisions.

UTILITIES: Call 1-800-424-5555 for utility locates at least two working days prior to starting any construction activity that could disturb the utility.

STATE PLANE COORDINATES: Stations shown on the bridge plans are state plane grid stations based on (NAD83-1992). Dimensions shown on the bridge plans are horizontal ground distances and not state plane grid distances. The combination scale factor (CSF) at this locations is 0.999249768.

Horizontal ground distance x CSF = Grid Distance
 Grid Distance/CSF = Distance to stake.

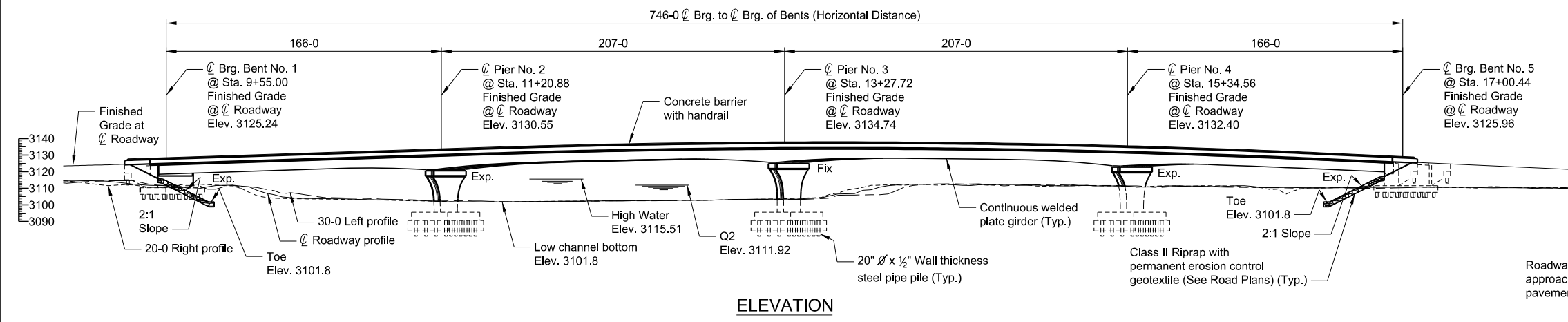
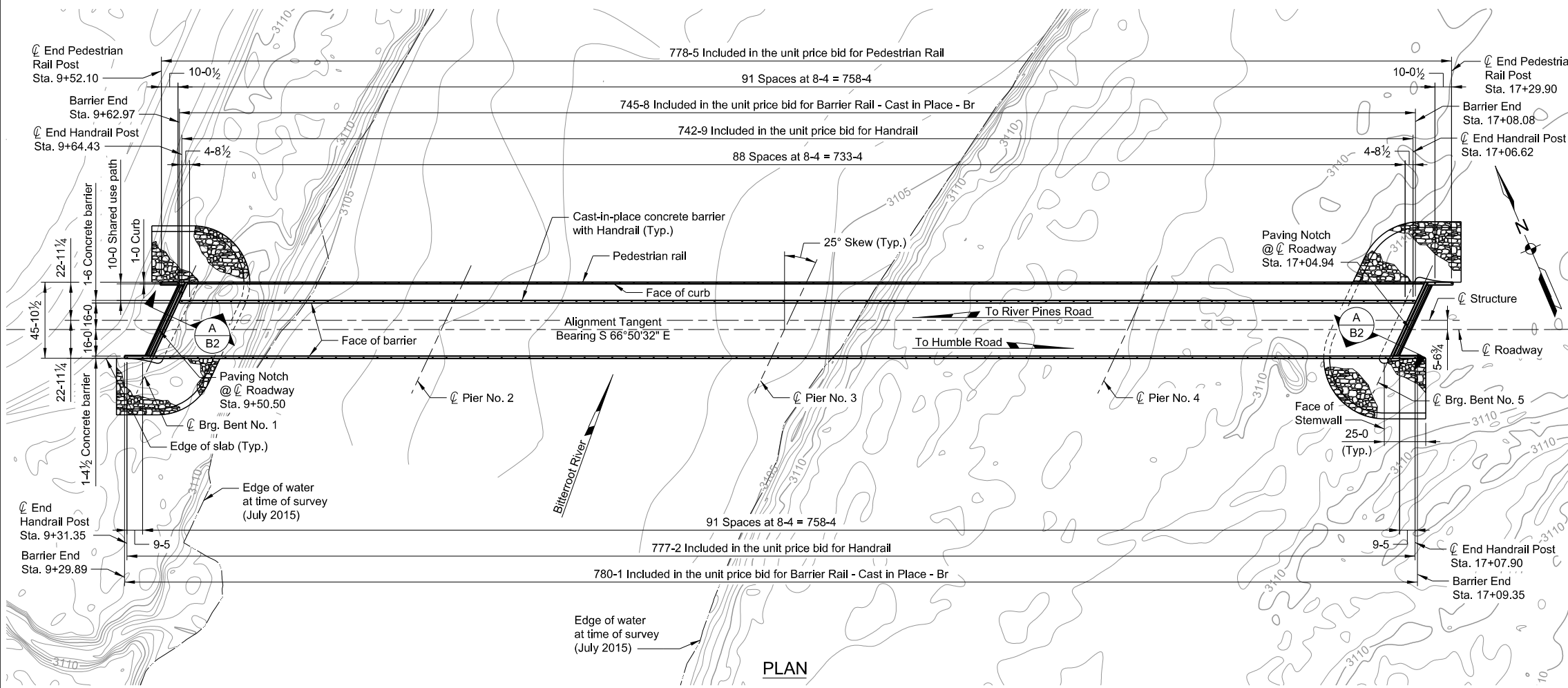

HYDRAULIC DATA

Drift:	High
Pier Scour (Q100):	11.4'
Contraction Scour (Q100):	0.0'
Ice:	Yes
Drainage Area:	2,842 sq. mi.
2-year Stage (Q2):	3111.92
Base Flood Flow (Q100):	31,800 cfs
Base Flood Stage:	3115.51
Base Flood Velocity:	4.6 fps
Low Beam Elevation:	3118.33

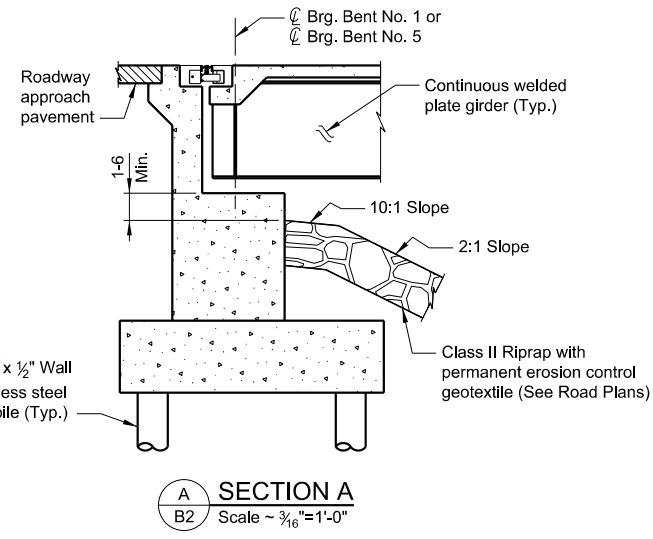

HDR



PLAN

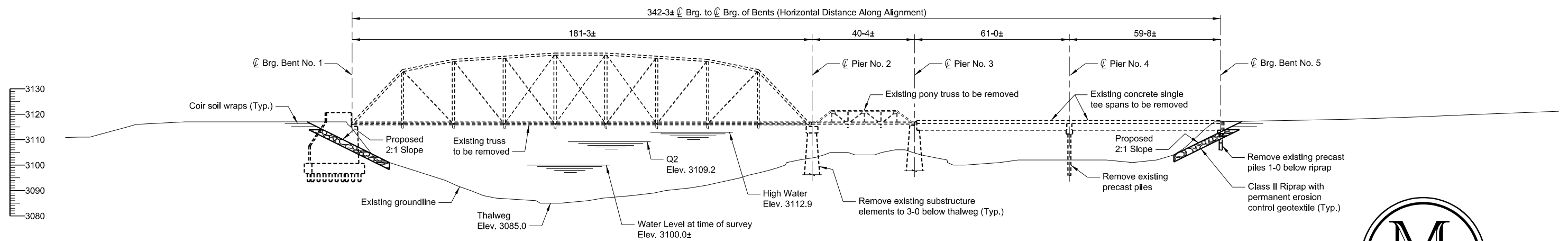

ELEVATION



**MACLAY BRIDGE REMOVAL
AND RIVER BANK RESTORATION**
JULY 2016
Scale 1" = 40'-0"



PRELIMINARY